

CONTENTS

ENGINE

Cylinder Head	B2
Crankshaft, Piston	B3
Air Shroud, Fan	B4
Oil Pump	B5
Intake	B6
Carburetor	B7
Exhaust	B8
Crankcase	B9
Starter	B10
Clutch	B11~B12
Transmission	B13

Generator	D3
Meter	D4
Headlight	D5
Taillight	D6
Handle Switch, Lever	D7
Electrical 1	D8
Electrical 2	D9

INDEX

Numerical Index	M1~M2
-----------------------	-------

CHASSIS

Frame	B14
Fender	B15
Side Cover	C2
Oil Tank	C3
Rear Suspension	C4
Front Fork	C5~C6
Fuel Tank	C7
Seat	C8
Front Wheel	C9
Front Brake Caliper	C10
Rear Wheel	C11
Steering Handle, Cable	C12
Front Master Cylinder	C13
Stand, Footrest	C14
Leg Shield	C15
Cowling 1	D2

YAMAHA

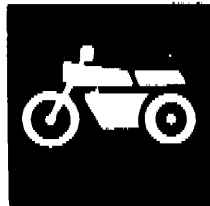

**PARTS
CATALOGUE**

YA50R (4PC1) ITALY
FORTE

MBK BRAND

244PC-354E1

YAMAHA
GENUINE
Parts & Accessories

A2

FOREWORD

This Parts Catalogue is related to the parts for the model(s) in the below frame. When you are ordering replacement parts, please refer to this Parts Catalogue and quote both part numbers and part names correctly.

YASOR FORTE (4PC1)

1. Modifications or additions which have been made after issue of the Parts Catalogue will be announced in the Yamaha Parts News.
It is advisable that you make necessary corrections to the Parts Catalogue according to the Yamaha Parts News.

2. Abbreviations

The following abbreviations are used in this Parts Catalogue.

- "UR" Use specified parts number.
- "UN" Use as many as needed.
- "AP" Alternate Parts
- "LM" Local Made (Parts need to be ordered locally)
- "F# " Frame No. (Applicable machine No.)

3. Parts, which are to be supplied in an assembly, are listed with a dot (.) in front of the part name as shown below.

EXAMPLE

CARBURETOR ASSY
 . JET, PILOT
 . NOZZLE, MAIN

4. Number of component for assembly

The numeral appearing to the right of each component part indicates the quantity of parts for each assembly unit.

EXAMPLE

PART NO.	DESCRIPTION	Q'TY	REMARKS
2F5-83310-60	FRONT FLASHER LIGHT ASSY	2	
115-83311-60	. BULB (6V-18W)	1	

5. Applicable colors of graphics are represented in the "REMARKS" as shown below.

PART NO.	DESCRIPTION	Q'TY	REMARKS
ZN4-24110-00-XS	FUEL TANK COMP.	1	MAXIM RED
3J1-24210-10	. GRAPHIC, FUEL TANK	1	for MXR

6. Applicable Serial No. and Color Code

①	Frame Serial No.	4PC-000108	~
②	Engine Serial No.	4PC-000108	~

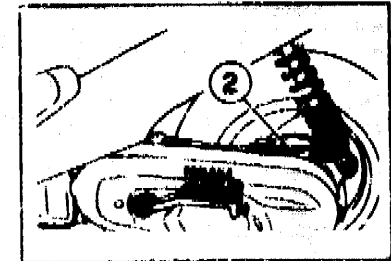
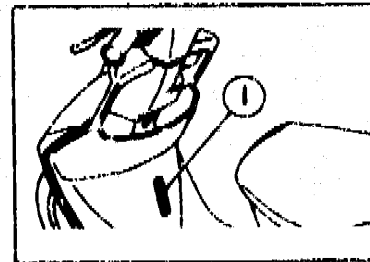

Color Code	Color Name	Abbreviation
009G	FROST SILVER	FRS
0479	SPANISH DARK GREEN COCKTAIL 1	SDGC1

7. Note that the illustrations are for reference in finding parts numbers, not to be used for assembling. When assembling, please use the applicable service manual.
8. The asterisk (*), before a reference number indicates modification items after the first edition.

A3

CONTENTS

ENGINE

Cylinder Head	B2
Crankshaft, Piston	B3
Air Shroud, Fan	B4
Oil Pump	B5
Intake	B6
Carburetor	B7
Exhaust	B8
Crankcase	B9
Starter	B10
Clutch	B11~B12
Transmission	B13

Generator	D3
Meter	D4
Headlight	D5
Taillight	D6
Handle Switch, Lever	D7
Electrical 1	D8
Electrical 2	D9

INDEX

Numerical Index	M1~M2
-----------------------	-------

CHASSIS

Frame	B14
Fender	B15
Side Cover	C2
Oil Tank	C3
Rear Suspension	C4
Front Fork	C5~C6
Fuel Tank	C7
Seat	C8
Front Wheel	C9
Front Brake Caliper	C10
Rear Wheel	C11
Steering Handle, Cable	C12
Front Master Cylinder	C13
Stand, Footrest	C14
Leg Shield	C15
Cowling 1	D2

CONTENTS

ENGINE

Cylinder Head	B2
Crankshaft. Piston	B3
Air Shroud. Fan	B4
Oil Pump	B5
Intake	B6
Carburetor	B7
Exhaust	B8
Crankcase	B9
Starter	B10
Clutch	B11~B12
Transmission	B13

CHASSIS

Frame	B14
Fender	B15
Side Cover	C2
Oil Tank	C3
Rear Suspension	C4
Front Fork	C5~C6
Fuel Tank	C7
Seat	C8
Front Wheel	C9
Front Brake Caliper	C10
Rear Wheel	C11
Steering Handle. Cable	C12
Front Master Cylinder	C13
Stand. Footrest	C14
Leg Shield	C15
Cowling 1	D2

Generator	D3
Meter	D4
Headlight	D5
Taillight	D6
Handle Switch. Lever	D7
Electrical 1	D8
Electrical 2	D9

INDEX

Numerical Index	M1~M2
-----------------------	-------

FIG. 1 CYLINDER HEAD

REF. NO.	PART NO.	DESCRIPTION	Q'TY	REMARKS
1	4CU-E1111-00	HEAD, CYLINDER 1	1	
2	4EF-E1181-00	GASKET, CYLINDER HEAD 1	1	
3	94701-00110	PLUG, SPARK (NGK BR7HS)	1	
4	4CU-E1311-00	CYLINDER 1	1	
5	4CU-E1351-00	GASKET, CYLINDER	1	
6	90116-07353	BOLT, STUD	4	
7	90179-07381	NUT	4	

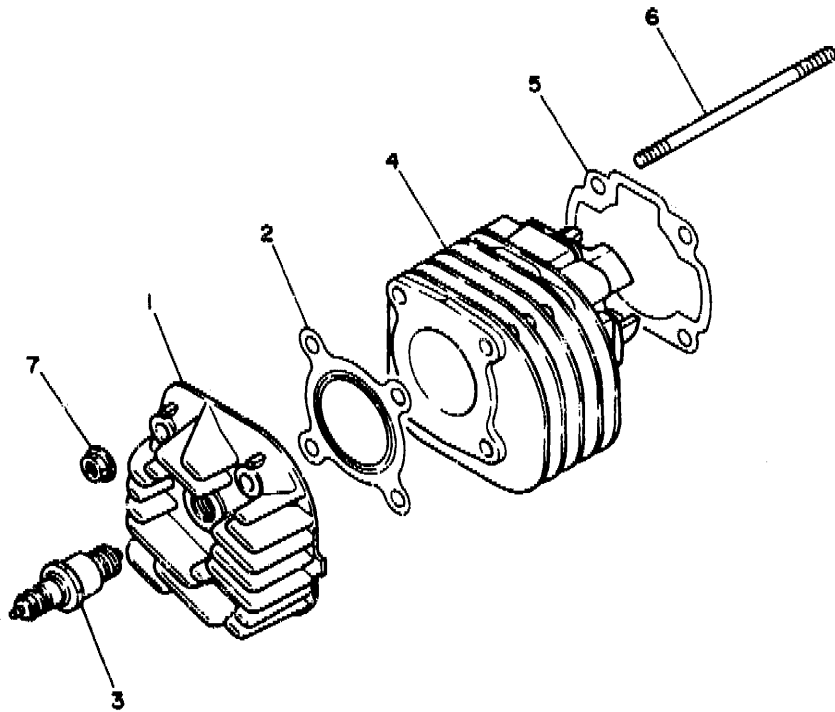

3XJ:010-9010

B2

FIG. 2 CRANKSHAFT. PISTON

REF. NO.	PART NO.	DESCRIPTION	Q'TY	REMARKS
1	4CU-E1400-00	CRANKSHAFT ASSY	1	
2	90280-03017	KCY, WOODRUFF	1	
3	93306-20458	BEARING	2	
4	93102-20371	O.I.L SEAL	1	
5	93101-20138	OIL SEAL	1	
6	90387-156U0	COLLAR	1	
7	3VL-E1631-00-96	PISTON (STD)	1	
	3VL-E1636-00	PISTON (0.50MM O/S)	1	AP
8	3VL-E1633-0J	PIN, PISTON	1	
9	3VL-E1610-00	PISTON RING SET (STD)	1	
	3VL-E1610-20	PISTON RING SET (0.50MM O/S)	1	AP
10	93450-11120	CIRCLIP	2	
11	93310-210M0	BEARING, CYLINDRICAL	1	

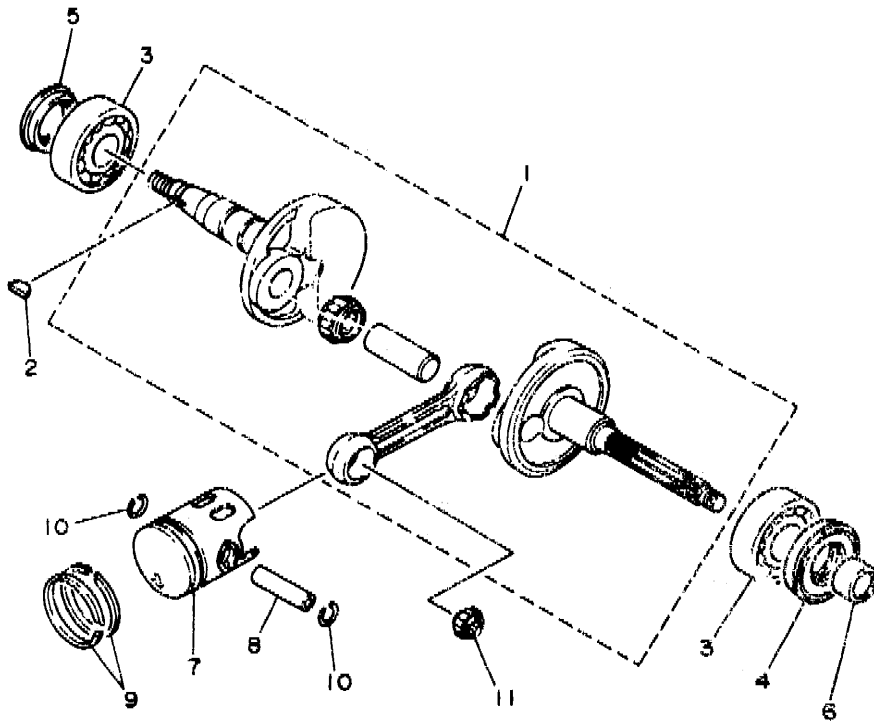

4PC1354-4020

B3

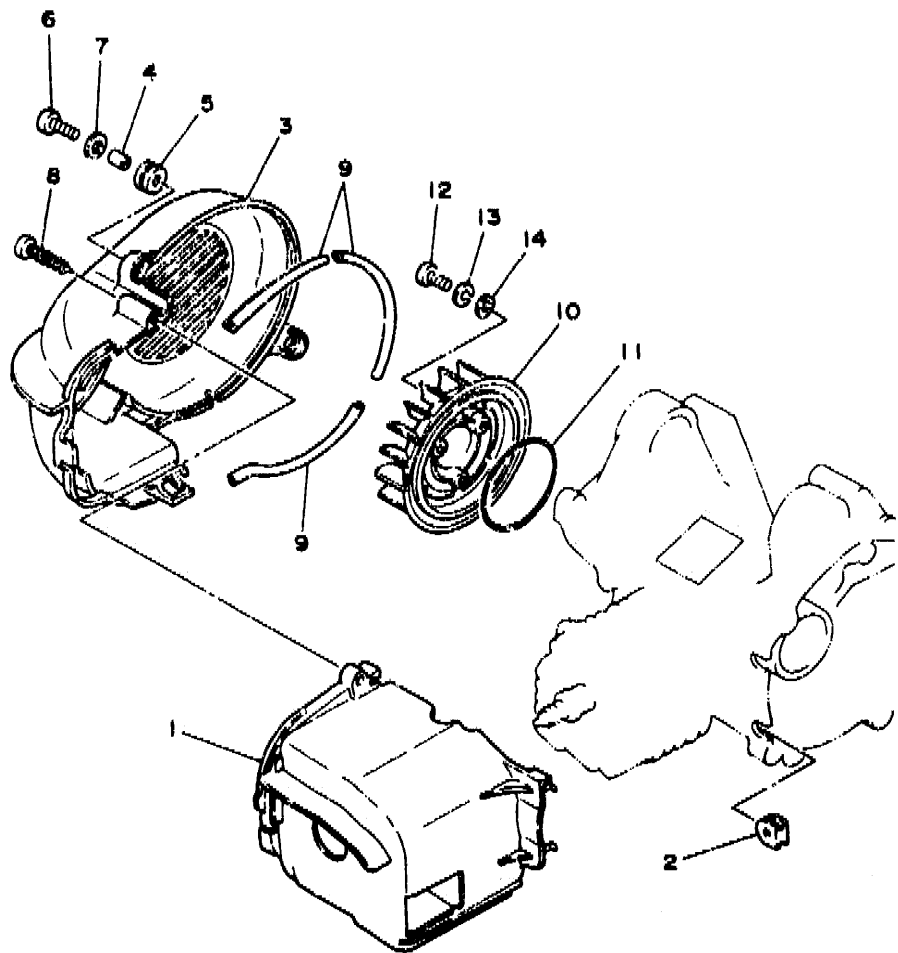

FIG. 3 AIR SHROUD. FAN

REF. NO.	PART NO.	DESCRIPTION	Q'TY	REMARKS
1	4CU-E2651-00	AIR SHROUD, CYLINDER 1	1	
2	90480-10468	GROMMET	2	
3	4CU-E2653-00	AIR SHROUD, CYLINDER 3	1	
4	90387-067V1	COLLAR	2	
5	90480-12497	GROMMET	2	
6	98507-06020	SCREW, PAN HEAD	2	
7	92907-06600	WASHER	2	
8	97707-60540	SCREW, TAPPING	1	
9	4CU-E2658-00	DAMPER, AIR SHROUD 1	3	
10	4CU-E2611-00	FAN	1	
11	93210-65752	O-RING	1	
12	98507-06016	SCREW, PAN HEAD	3	
13	92907-06100	WASHER	3	
14	92907-06600	WASHER	3	



3KJ1010-9030

B4

FIG. 4 OIL PUMP

REF. NO.	PART NO.	DESCRIPTION	Q'TY	REMARKS
1	3AA-13100-02	OIL PUMP ASSY	1	
2	3WF-13185-00	.BOLT, BREATHER	1	
3	1YU-13187-00	.GASKET, BREATHER BOLT	1	
4	1YU-13473-00	.O-RING	1	
5	3AA-13124-00	.GEAR WORM WHEEL (40T)	1	
6	1YU-13516-00	.PIN, DOWEL	1	
7	1YU-13577-00	.CLIP	1	
3	90445-09304	.HOSE	1	
9	90467-08003	.CLIP	2	
10	90445-05204	.HOSE	1	
11	90468-02033	.CLIP	1	
12	90468-02033	CLIP	1	
13	98507-05014	SCREW, PAN HEAD	2	
14	2GM-13178-00	GEAR, PUMP DRIVE	1	
15	93503-12007	PIN, DOWEL	1	
16	99009-19400	CIRCLIP	2	

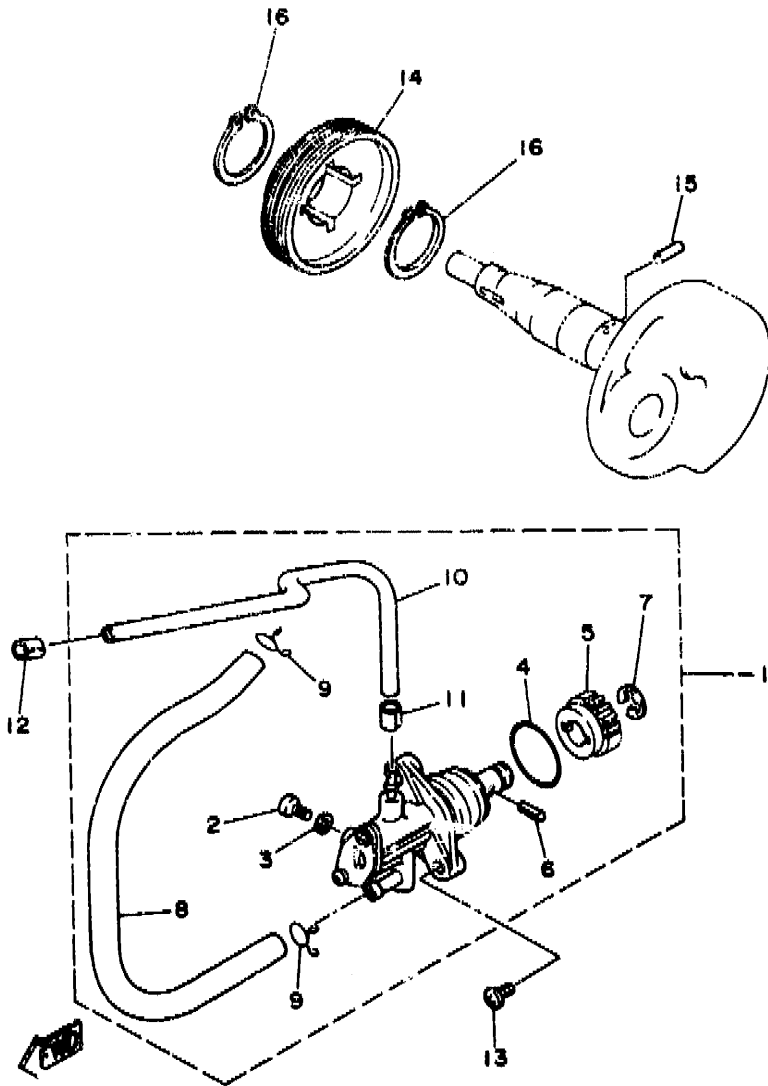

3KJ1010-8040

B5

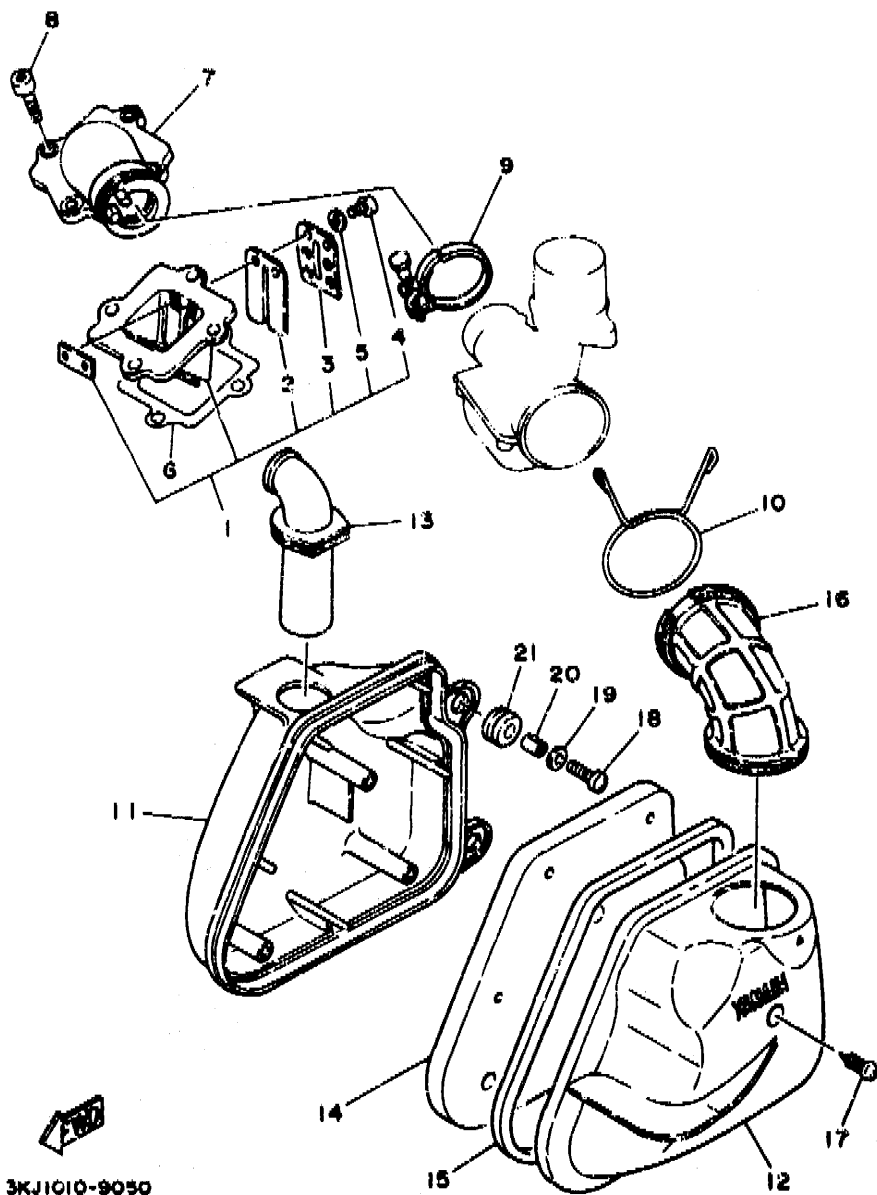

3KJ1010-9050

FIG. 5 INTAKE

REF. NO.	PART NO.	DESCRIPTION	Q'TY	REMARKS
1	4CU-E3610-00	REED VALVE ASSY	1	
2	4CU-E3613-00	.REED, VALVE	2	
3	4CU-E3616-00	.STOPPER, REED VALVE	2	
4	98507-03008	.SCREW, PAN HEAD	4	
5	92907-03600	.WASHER	4	
6	4CU-E3621-00	GASKET, VALVE SEAT	1	
7	4EE-E3555-00	MANIFOLD, INTAKE	1	
8	91316-06020	BOLT	4	
9	90460-32242	CLAMP, HOSE	1	
10	90467-24140	CLIP	1	
11	3WG-E4411-00	CASE, AIR CLEANER 1	1	
12	3WG-E4412-00	CAP, CLEANER CASE 1	1	
13	3WG-E4437-00	DUCT	1	
14	3WG-E4451-00	ELEMENT, AIR CLEANER	1	
15	3WG-E4452-00	SEAL	1	
16	3WG-E4453-00	JOINT, AIR CLEANER 1	1	
17	97707-50125	SCREW, TAPPING	3	
18	98507-06020	SCREW, PAN HEAD	2	
19	90201-06815	WASHER, PLATE	2	
20	90387-068C7	COLLAR	2	
21	90480-12497	GROMMET	2	

B6

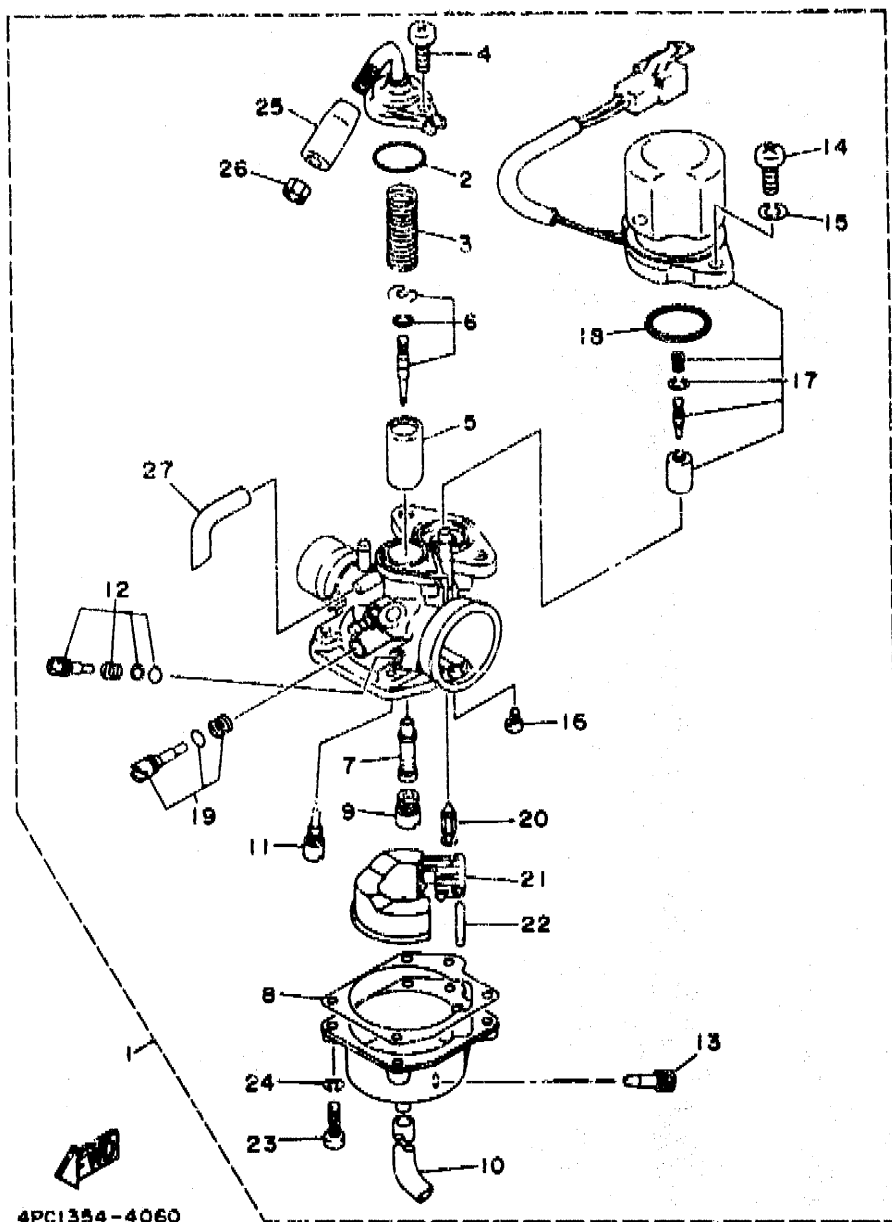

4PC1354-4060

FIG. 6 CARBURETOR

REF. NO.	PART NO.	DESCRIPTION	Q'TY	REMARKS
1	4FK-14301-15	CARBURETOR ASSY 1	1	
2	4JP-14561-00	.O-RING	1	
3	1YU-14331-00	.SPRING, THROTTLE VALVE	1	
4	98580-05014	.SCREW, PAN HEAD	1	
5	3KJ-14312-30	.VALVE, THROTTLE 1	1	
6	4FK-1490J-01	.NEEDLE SET	1	
7	33A-14341-00	.NOZZLE, MAIN	1	
8	14T-14384-00	.GASKET, FLOAT CHAMBER	1	
9	14T-14343-39	.JET, MAIN (#78)	1	
10	3KJ-14349-01	.PIPE	1	
11	3KJ-14353-22	.JET, PILOT (#44)	1	
12	4JP-14104-00	.AIR SCREW SET	1	
13	14T-14104-00	.AIR SCREW SET	1	
14	98580-06016	.SCREW, PAN HEAD	2	
15	92995-06100	.WASHER, SPRING	2	
16	98580-03006	.SCREW, PAN HEAD	1	
17	3KJ-1410A-10	.STARTER SET	1	
18	1HV-14.47-00	.O-RING	1	
19	3YJ-14103-00	.THROTTLE SCREW SET	1	
20	2JA-14392-00	.VALVE, NEEDLE	1	
21	1HV-14385-01	.FLOAT	1	
22	367-14386-00	.PIN, FLOAT	1	
23	98580-04016	.SCREW, PAN HEAD	4	
24	92901-04100	.WASHER, SPRING	4	
25	3KJ-26329-00	.CAP, RUBBER	1	
26	288-14161-00	.NUT, CABLE ADJUSTING	1	
27	2JA-14397-00	.PIPE	1	

B7

FIG. 7 EXHAUST

REF. NO.	PART NO.	DESCRIPTION	Q'TY	REMARKS
1	4KH-14610-00	EXHAUST PIPE ASSY 1	1	
2	97707-30605	SCREW, TAPPING	1	
3	3HK-14613-00	GASKET, EXHAUST PIPE	1	
4	4PC-E4617-00	WASHER	2	
5	90149-06113	SCREW	2	
6	95817-08040	BOLT, FLANGE	1	
7	95817-08030	BOLT, FLANGE	1	
8	3WG-E4718-R0	PROTECTOR, MUFFLER 1	1	
9	3WG-E4766-00	WASHER, PROTECTOR	2	
10	92907-06200	WASHER	2	
11	98907-06016	SCREW, BIND	2	
12	90480-12237	GROMMET	2	
13	90387-06067	COLLAR	2	
14	3WG-E4766-10	WASHER, PROTECTOR	2	

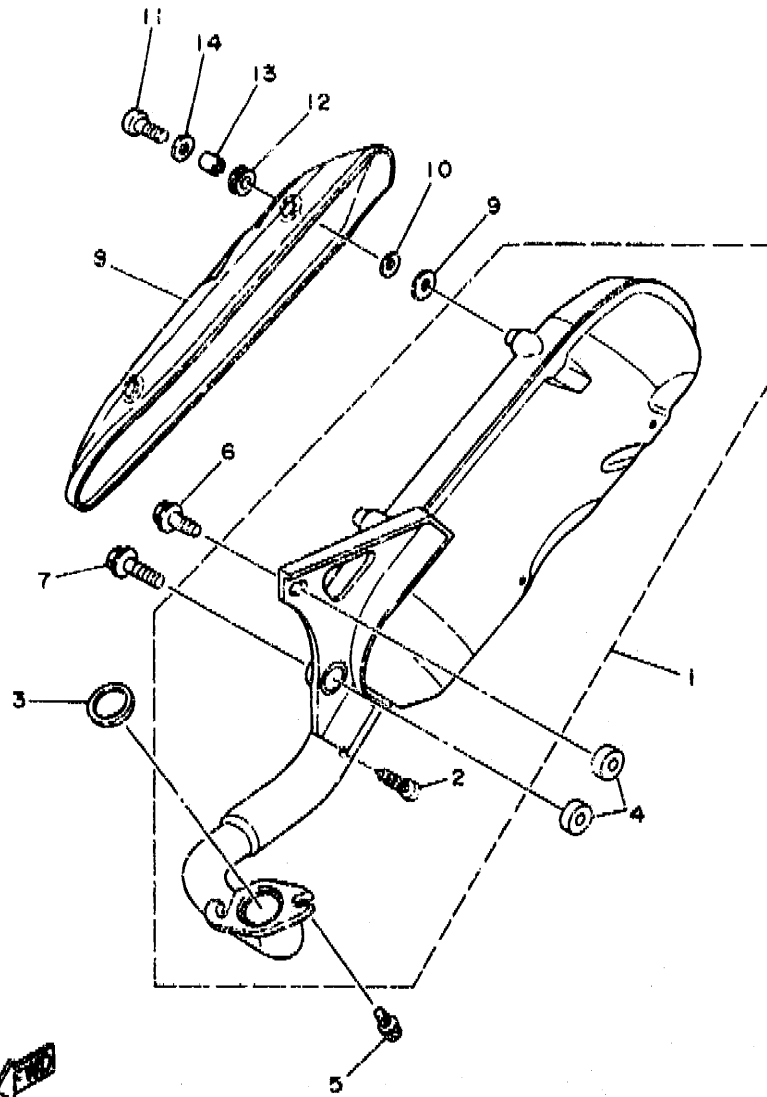

4PC1354-4070

B8

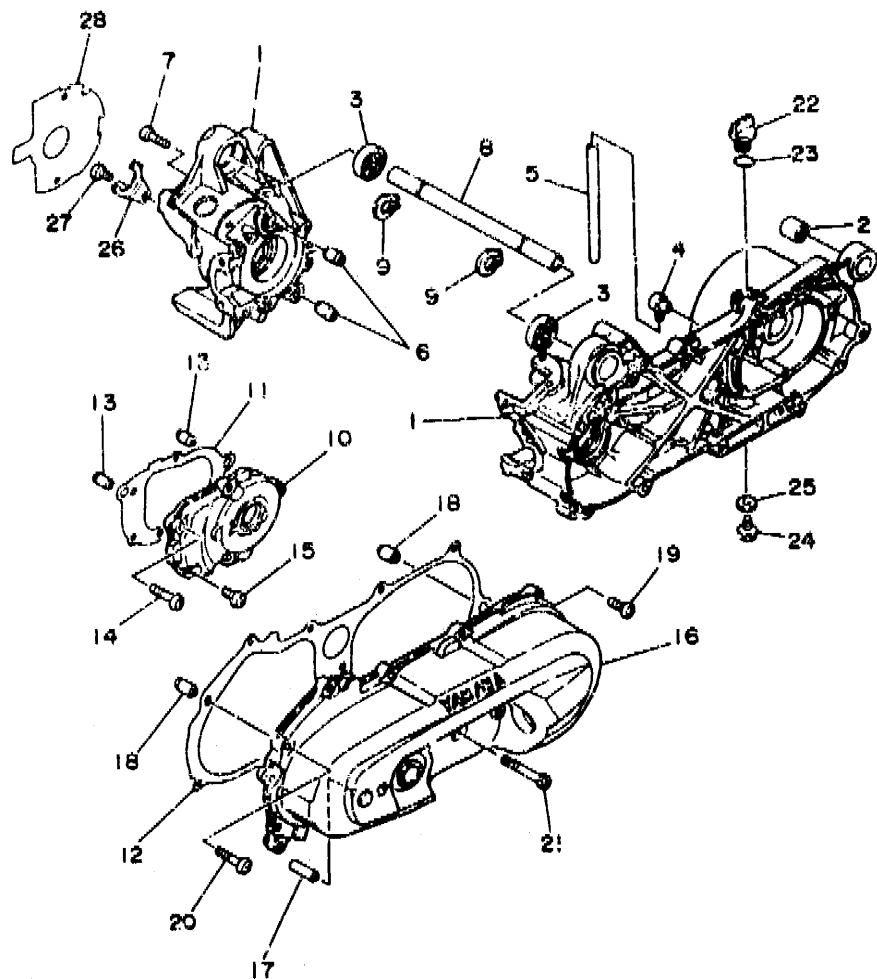

4PC1354-4080

FIG. 8 CRANKCASE

REF. NO.	PART NO.	DESCRIPTION	Q'TY	REMARKS
1	4CU-E5150-00	CRANKCASE ASSY	1	
2	164-22216-00	BUSH, REAR SHOCK ABSORBER	1	
3	93306-00316	BEARING	2	
4	4CU-E5371-00	BREATHER	1	
5	91A20-07014	TUBE, FLEXIBLE VINYL	1	
6	99510-12016	PIN, DOWEL	2	
7	98507-06035	SCREW, PAN HEAD	6	
8	4CU-E5317-00	SPACER, ENGINE MOUNT	1	
9	99009-17400	CIRCLIP	2	
10	4CU-E5421-00	COVER, CRANKCASE 2	1	
11	4CU-E5461-00	GASKET, CRANKCASE COVER 2	1	
12	4CU-E5451-00	GASKET, CRANKCASE COVER 1	1	
13	99530-10014	PIN, DOWEL	2	
14	98507-06035	SCREW, PAN HEAD	2	
15	98507-06020	SCREW, PAN HEAD	3	
16	4CU-E5411-00	COVER, CRANKCASE 1	1	
17	4CU-E5659-00	SHAFT	1	
18	99530-10014	PIN, DOWEL	2	
19	98507-06025	SCREW, PAN HEAD	8	
20	98507-06035	SCREW, PAN HEAD	2	
21	98507-06065	SCREW, PAN HEAD	1	
22	3VL-E5363-00	PLUG, OIL	1	
23	93210-14104	O-RING	1	
24	95807-08016	BOLT, FLANGE	1	
25	90201-08087	WASHER, PLATE	1	
26	3VL-E5128-00	HOLDER	1	
27	98507-06012	SCREW, PAN HEAD	1	
28	4CU-E5462-00	GASKET, CRANKCASE COVER 3	1	

B9

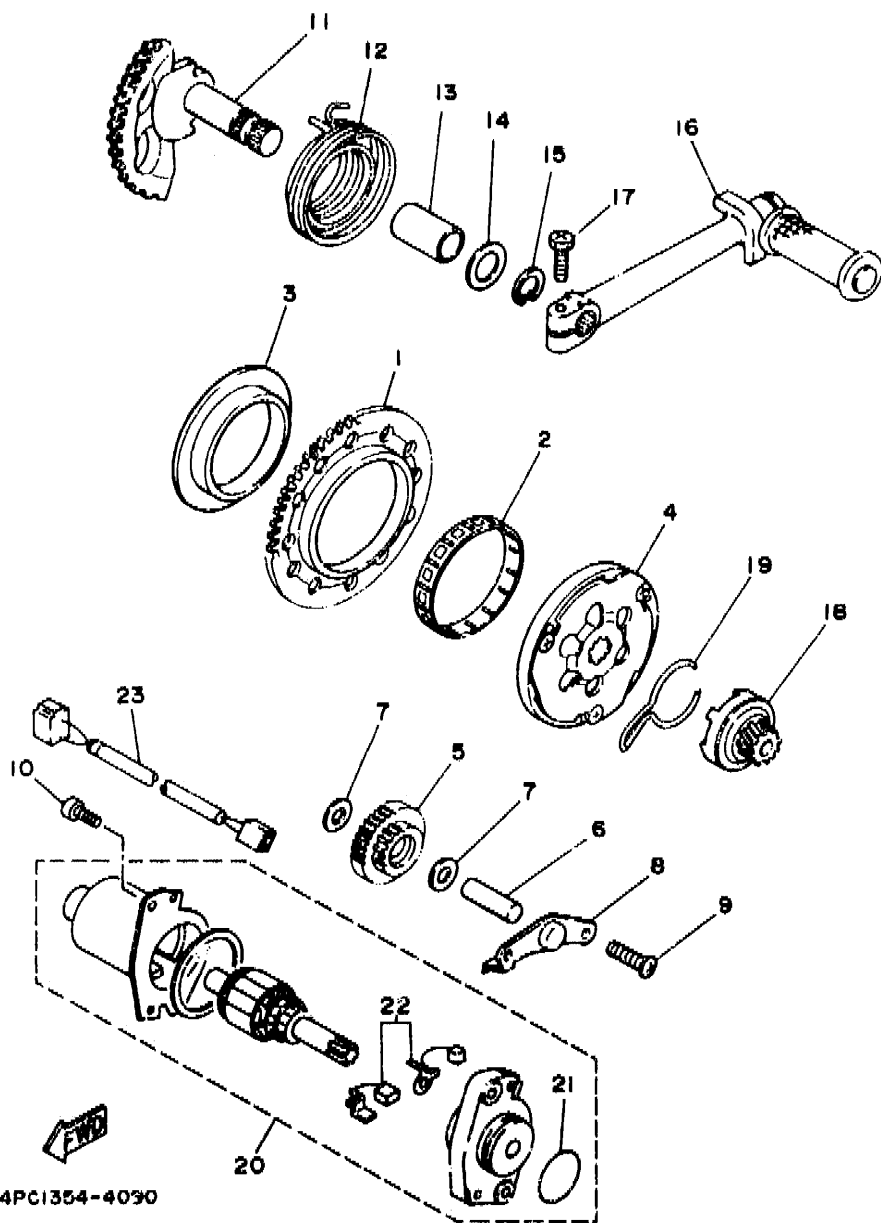

4PC1354-4090

FIG. 9 STARTER

REF. NO.	PART NO.	DESCRIPTION	Q'TY	REMARKS
1	3AA-15513-00	GEAR 1 (71T)	1	
2	93310-257R1	BEARING, CYLINDRICAL	1	
3	3KJ-15528-00	BOSS, GEAR	1	
4	3VL-15570-00	STARTER CLUTCH ASSY	1	
5	4CU-E5650-00	IDLE GEAR ASSY	1	
6	3VL-E5659-00	SHAFT	1	
7	90201-08088	WASHER, PLATE	2	
8	4CU-E5532-00	PLATE, IDLE GEAR	1	
9	98507-06012	SCREW, PAN HEAD	2	
10	91316-06020	BOLT	2	
11	3KJ-15601-00	KICK SHAFT ASSY	1	
12	90508-32609	SPRING, TORSION	1	
13	90380-15083	BUSH, SOLID	1	
14	90201-154E9	WASHER, PLATE	1	
15	99009-15400	CIRCLIP	1	
16	3WG-E5620-00	KICK CRANK ASSY	1	
17	90153-06052	SCREW, HEXAGON	1	
18	1NT-15630-01	KICK PINION ASSY	1	
19	4CU-E5673-00	CLIP	1	
20	3YJ-81800-01	STARTING MOTOR ASSY	1	YAMAHA
21	93210-23614	O-RING	1	
22	1YU-81801-M0	BRUSH SET	1	
23	3WG-H2541-00	WIRE, LEAD	1	

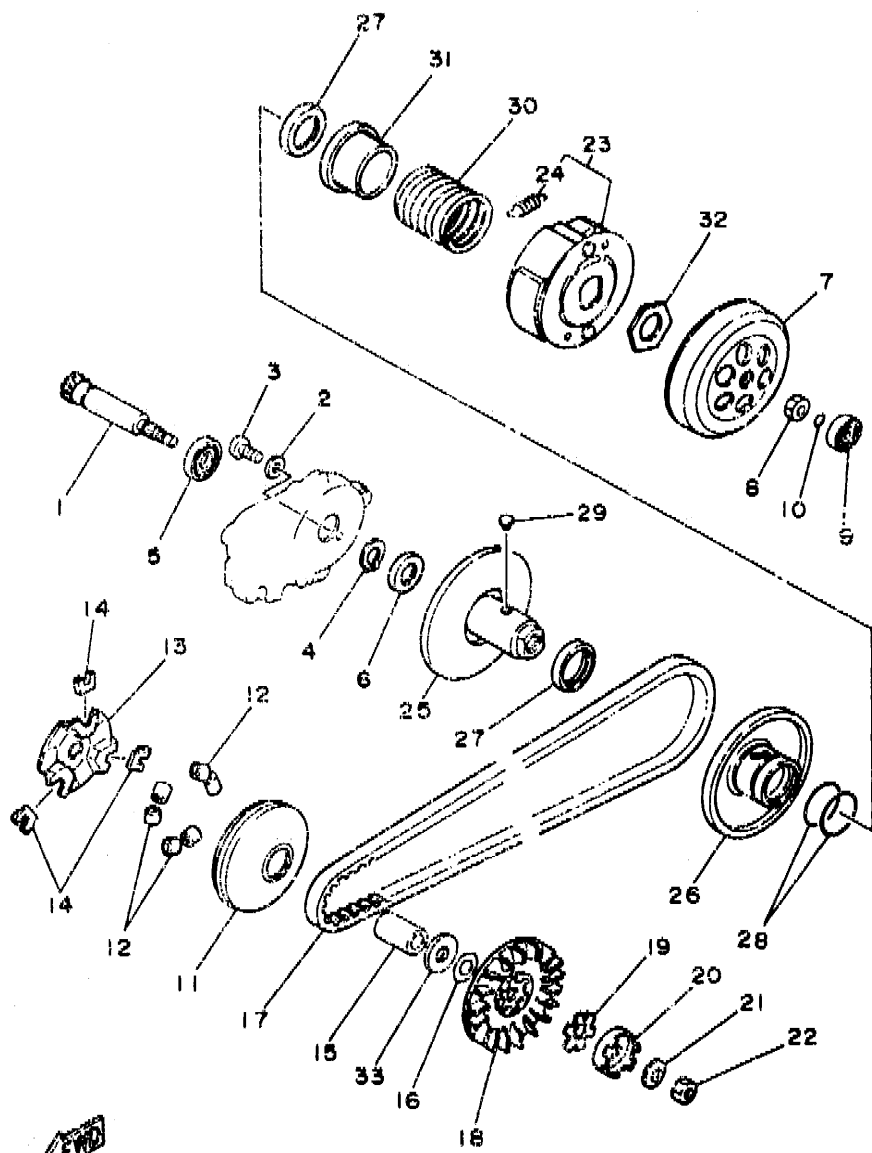

4PC1354-4100

FIG. 10 CLUTCH

REF. NO.	PART NO.	DESCRIPTION	Q'TY	REMARKS
1	4CU-E6111-00	GEAR, PRIMARY DRIVE	1	
2	90201-06412	WASHER, PLATE	1	
3	98507-06010	SCREW, PAN HEAD	2	
4	99009-17400	CIRCLIP	1	
5	93306-C0302	BEARING (B600303)	1	
6	93102-17342	OIL SEAL	1	
7	3YJ-16611-00	CLUTCH HOUSING COMP.	1	
8	90170-10317	NUT	1	
9	93300-83813	BEARING	1	
10	93210-06550	O-RING	1	
11	4CU-E7620-00	PRIMARY SLIDING SHEAVE COMP.	1	
12	4CU-E7632-00	WEIGHT	6	
13	3VL-E7623-00	CAM	1	
14	1NT-17653-00	SLIDER	3	
15	90387-13509	COLLAR	1	
16	90201-136P4	WASHER, PLATE	1	
17	3VP-17641-00	V-BELT	1	
18	3VL-E7611-00	SHEAVE, PRIMARY FIXED	1	
19	90214-13055	WASHER, CLAW	1	
20	3VL-E5657-00	CLUTCH, ONEWAY	1	
21	90208-10012	WASHER, CONICAL SPRING	1	
22	90170-10219	NUT	1	
23	4CX-16620-00	CLUTCH CARRIER ASSY	1	
24	17L-16626-00	SPRING, CLUTCH WEIGHT 1	1	
25	3GF-17660-02	SECONDARY FIXED SHEAVE COMP.	1	
26	3WG-17608-00	SECONDARY SLIDING SHEAVE	1	
27	93109-33052	OIL SEAL	2	
28	93210-36657	O-RING	2	

B11

FIG. 10 CLUTCH

REF. NO.	PART NO.	DESCRIPTION	Q'TY	REMARKS
29	24G-17664-00	PIN, GUIDE	2	
30	90501-357F3	SPRING, COMPRESSION	1	
31	3KJ-17684-00	SEAT, SECONDARY SPRING	1	
32	90179-28415	NUT	1	
33	4EF-E7654-00	SPACER 1	1	

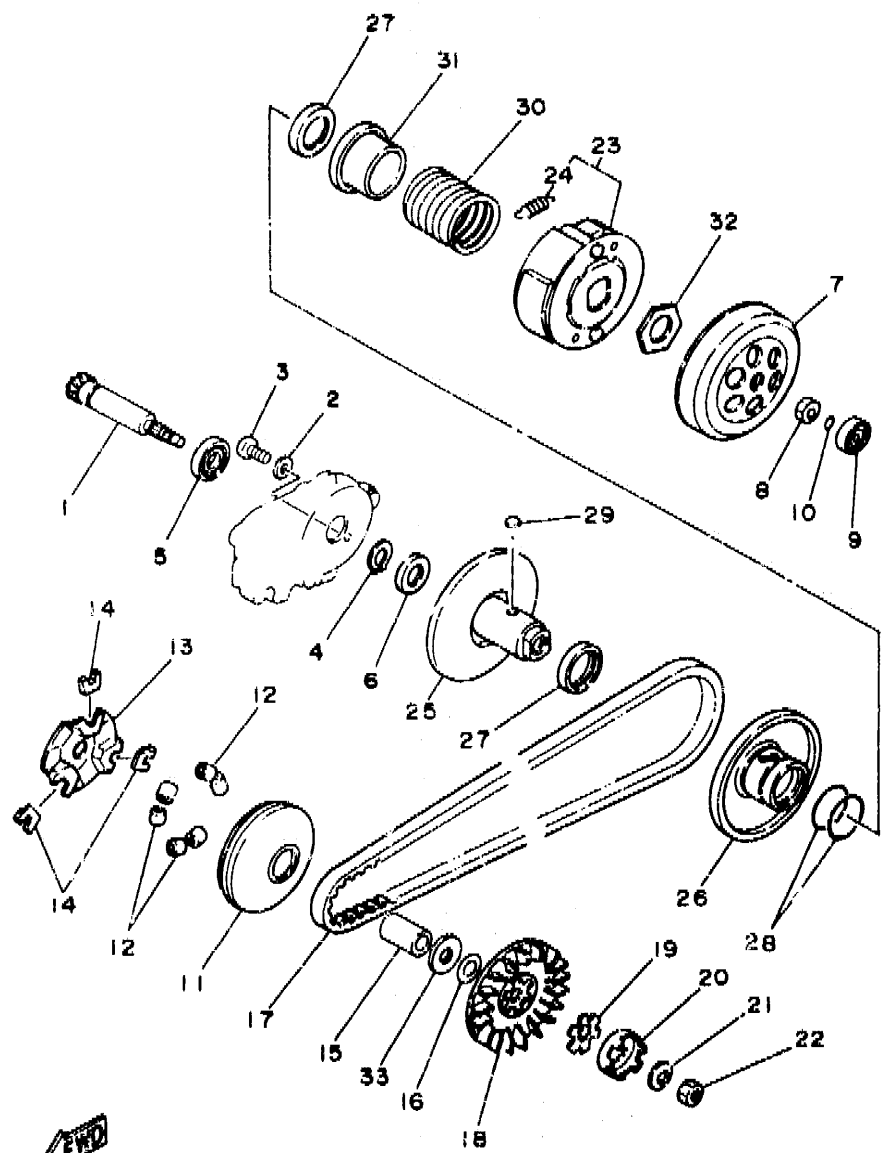

4PC1354-4100

B12

FIG. 11 TRANSMISSION

REF. NO.	PART NO.	DESCRIPTION	Q'TY	REMARKS
1	4CU-E7410-00	MAIN AXLE COMP.	1	
2	93306-20006	BEARING (B6200)	1	NTN
3	90201-123K4	WASHER, PLATE	1	
4	90208-12049	WASHER, CONICAL SPRING	1	
5	4CU-E7420-00	DRIVE AXLE ASSY	1	
6	93306-20346	BEARING	1	
7	93102-22314	OIL SEAL	1	
8	93420-40064	CIRCLIP	1	

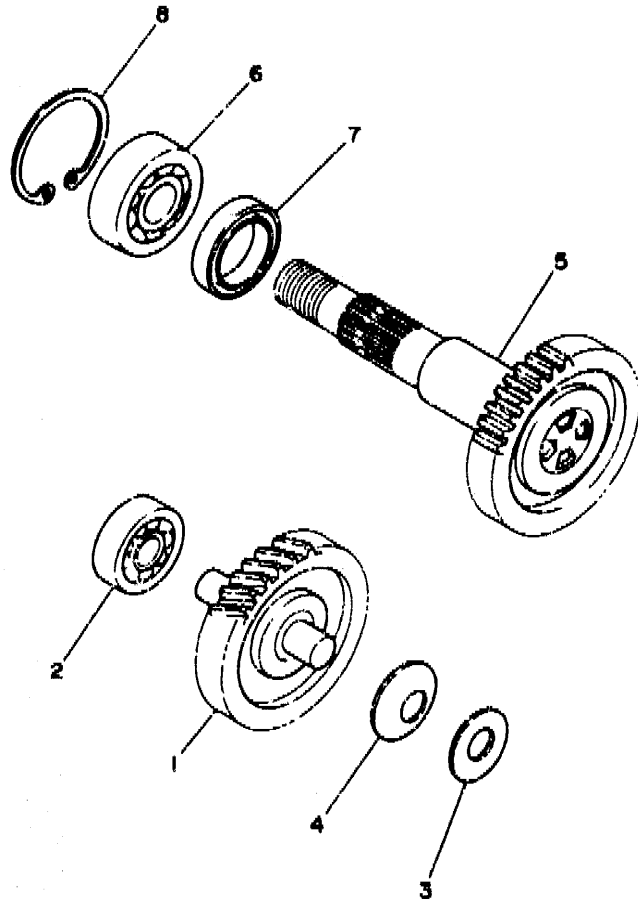

 3KJ1010-9110

B13

FIG. 12 FRAME

REF. NO.	PART NO.	DESCRIPTION	Q'TY	REMARKS
1	4PC-F1110-00	FRAME COMP.	1	
2	3WG-F1481-00	BOLT, ENGINE MOUNTING 1	1	
3	95607-12200	NUT, SELF-LOCKING	1	
4	3WG-F1481-10	BOLT, ENGINE MOUNTING 1	2	
5	90135-10154	NUT, SELF-LOCKING	2	
6	31G-F1410-00	ENGINE BRACKET COMP.	1	
7	3WG-F139X-00	DAMPER	2	
8	90501-29517	SPRING, COMPRESSION	2	
9	4MJ-F1232-00	REINFORCEMENT, TAIL	1	
10	95807-06012	BOLT, FLANGE	4	
11	4MJ-F117M-00	COVER 2	2	

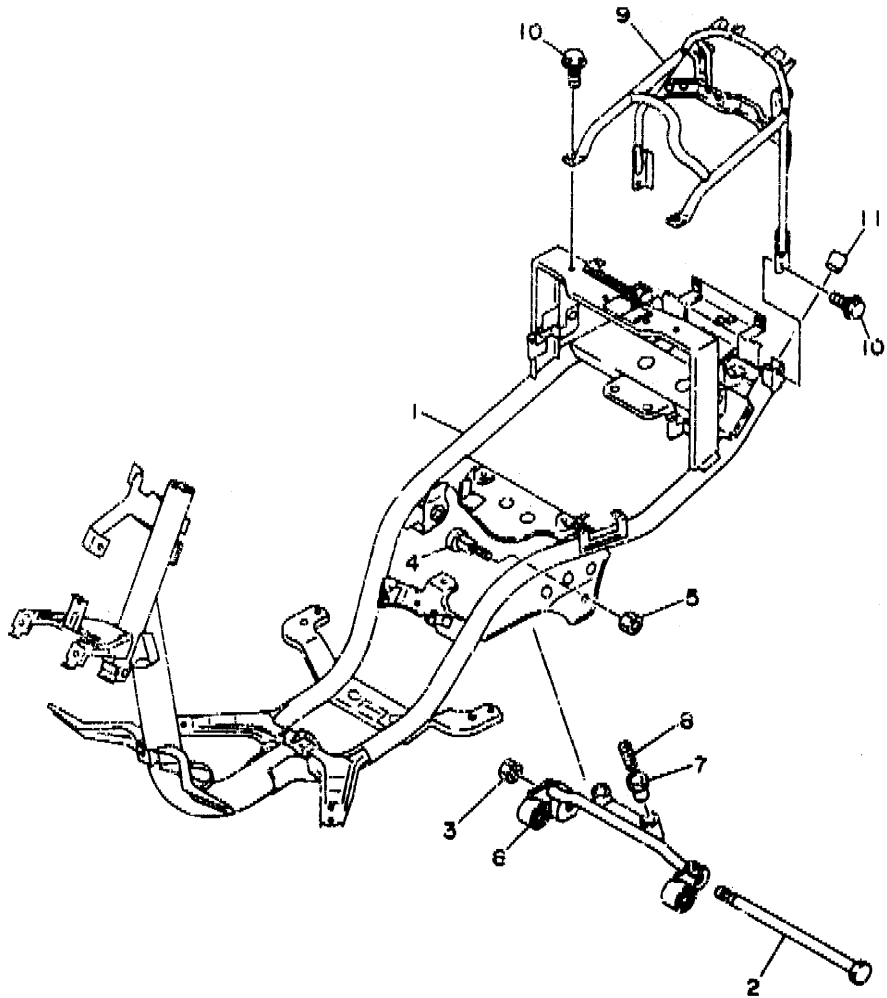

4MJ1352-4120

B14

FIG. 13 FENDER

REF. NO.	PART NO.	DESCRIPTION	Q'TY	REMARKS
1	4PC-X1511-00-P1	FENDER, FRONT	1	UR SPANISH DARK GREEN COCKTAIL 1
	4PC-X1511-00-9G	FENDER, FRONT	1	UR FROST SILVER
2	4PC-F1571-00	.EMBLEM3	1	UR FOR FRS
	4PC-F1571-10	.EMBLEM3	1	UR FOR SDGC1
3	4PC-F1572-00	.EMBLEM4	1	UR FOR FRS
	4PC-F1572-10	.EMBLEM4	1	UR FOR SDGC1
4	4CU-F8315-00	.EMBLEM, MBK	1	
5	4PC-F1552-00	FENDER, INNER	1	
6	3WG-F1553-00	FENDER, INNER 2	1	
7	95807-06012	BOLT, FLANGE	1	
8	90119-06044	BOLT, WITH WASHER	2	
9	90163-05006	SCREW, TAPPING	2	

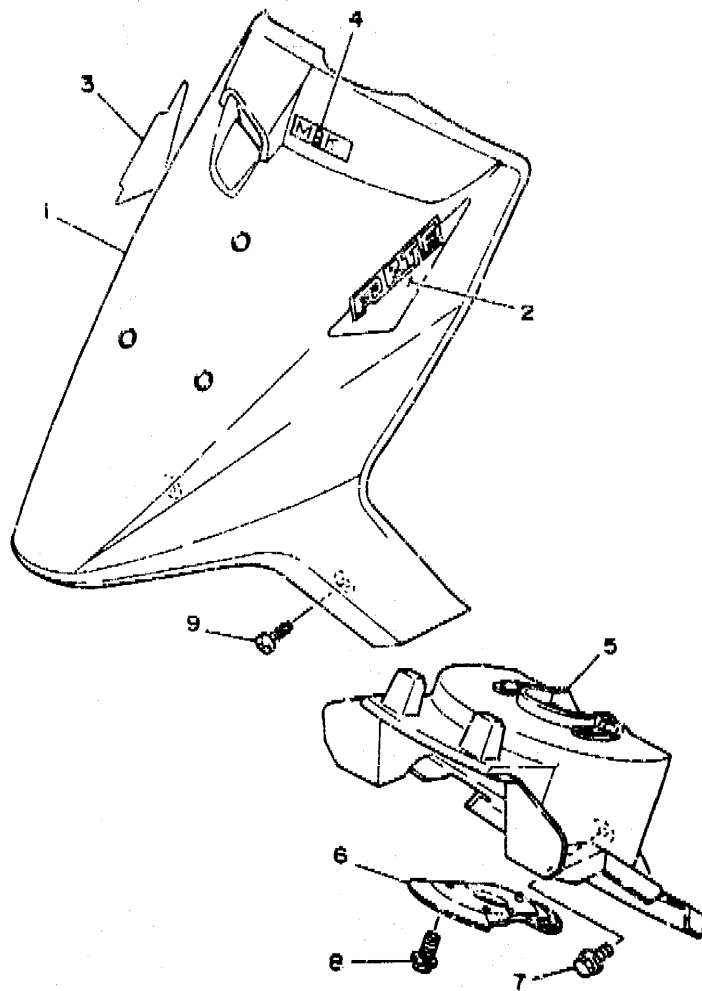

4PC1354-4130

B15

CONTENTS

ENGINE

Cylinder Head	B2
Crankshaft, Piston	B3
Air Shroud, Fan	B4
Oil Pump	B5
Intake	B6
Carburetor	B7
Exhaust	B8
Crankcase	B9
Starter	B10
Clutch	B11~B12
Transmission	B13

Generator	D3
Meter	D4
Headlight	D5
Taillight	D6
Handle Switch, Lever	D7
Electrical 1	D8
Electrical 2	D9

INDEX

Numerical Index	M1~M2
-----------------------	-------

CHASSIS

Frame	B14
Fender	B15
Side Cover	C2
Oil Tank	C3
Rear Suspension	C4
Front Fork	C5~C6
Fuel Tank	C7
Seat	C8
Front Wheel	C9
Front Brake Caliper	C10
Rear Wheel	C11
Steering Handle, Cable	C12
Front Master Cylinder	C13
Stand, Footrest	C14
Leg Shield	C15
Cowling 1	D2

CONTENTS

ENGINE

Cylinder Head	B2
Crankshaft. Piston	B3
Air Shroud. Fan	B4
Oil Pump	B5
Intake	B6
Carburetor	B7
Exhaust	B8
Crankcase	B9
Starter	B10
Clutch	B11~B12
Transmission	B13

Generator	D3
Meter	D4
Headlight	D5
Taillight	D6
Handle Switch. Lever	D7
Electrical 1	D8
Electrical 2	D9

INDEX

Numerical Index	M1~M2
-----------------------	-------

CHASSIS

Frame	B14
Fender	B15
Side Cover	C2
Oil Tank	C3
Rear Suspension	C4
Front Fork	C5~C6
Fuel Tank	C7
Seat	C8
Front Wheel	C9
Front Brake Caliper	C10
Rear Wheel	C11
Steering Handle. Cable	C12
Front Master Cylinder	C13
Stand. Footrest	C14
Leg Shield	C15
Cowling 1	D2

FIG. 14 SIDE COVER

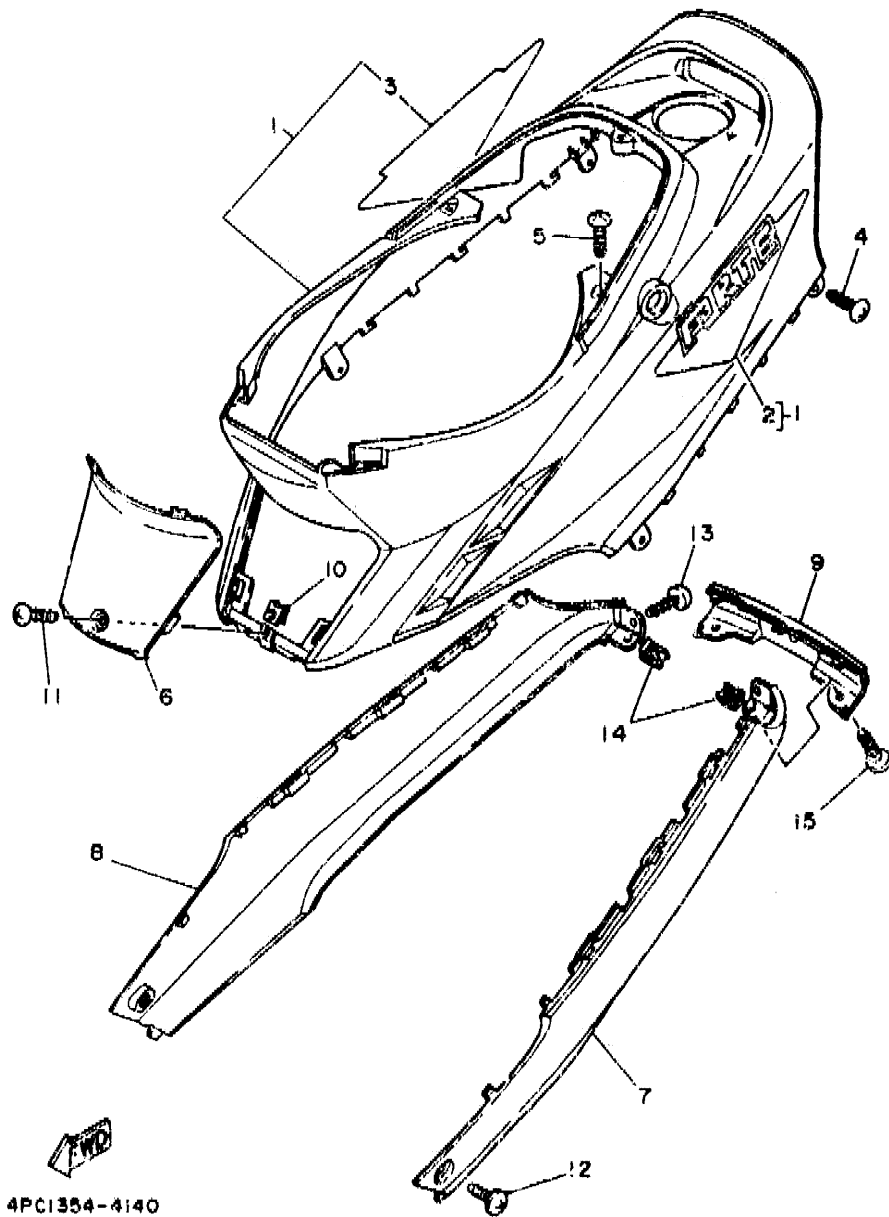

4PC1354-4140

REF. NO.	PART NO.	DESCRIPTION	QTY	REMARKS
1	4PC-X1711-00-P1	COVER, SIDE 1	1	UR SPANISH DARK GREEN COCKTAIL 1
	4PC-X1711-00-9G	COVER, SIDE 1	1	UR FROST SILVER
2	4PC-F1782-00	.EMBLEM 2	1	UR FOR FRS
	4PC-F1782-10	.EMBLEM 2	1	UR FOR SDGC1
3	4PC-F1783-00	.EMBLEM 3	1	UR FOR FRS
	4PC-F1783-10	.EMBLEM 3	1	UR FOR SDGC1
4	90167-05041	SCREW, TAPPING	4	
5	97707-50016	SCREW, TAPPING	3	
6	3VP-F1721-00-P1	COVER, SIDE 2	1	UR SPANISH DARK GREEN COCKTAIL 1
	3VP-F1721-00-9G	COVER, SIDE 2	1	UR FROST SILVER
7	4PC-F171L-00	MOLE, SIDE COVER 1	1	UR GRAY
	4PC-F171L-10	MOLF, SIDE COVER 1	1	UR BLACK
8	4PC-F171M-00	MOLE, SIDE COVER 2	1	UR GRAY
	4PC-F171M-10	MOLE, SIDE COVER 2	1	UR BLACK
9	4MJ-F171N-00	MOLE, SIDE COVER 3	1	UR GRAY
	4MJ-F171N-10	MOLE, SIDE COVER 3	1	UR BLACK
10	90183-05042	NUT, SPRING	1	
11	90167-05055	SCREW, TAPPING	1	
12	90149-06184	SCREW	2	
13	97707-50016	SCREW, TAPPING	2	
14	90183-05042	NUT, SPRING	2	
15	90167-05041	SCREW, TAPPING	2	

C2

FIG. 15 OIL TANK

REF. NO.	PART NO.	DESCRIPTION	Q'TY	REMARKS
1	4MJ-F1751-00	TANK, OIL	1	
2	3WG-F1771-00	BODY, CAP	1	
3	90119-06042	BOLT, WITH WASHER	2	

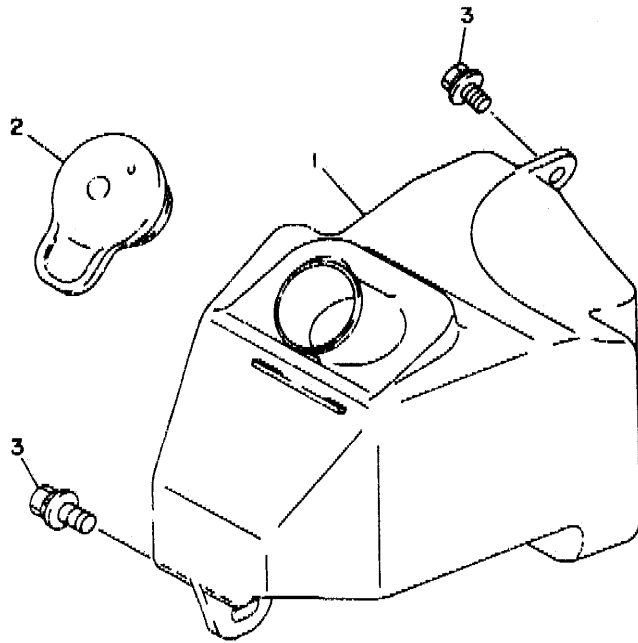

4MJ1352-4150

C3

FIG. 16 REAR SUSPENSION

REF. NO.	PART NO.	DESCRIPTION	Q'TY	REMARKS
1	4PC-F2210-00	SHOCK ABSORBER ASSY, REAR	1	
2	90105-08121	BOLT, WASHER BASED	1	
3	3WG-F2241-00	BOLT 1	1	
4	90185-10822	NUT, SELF-LOCKING	1	
5	90468-12006	CLIP	1	
6	3WG-F13B1-00	BRACKET, REAR SHOCK ABSORBER	1	
7	95827-08012	BOLT, FLANGE	2	

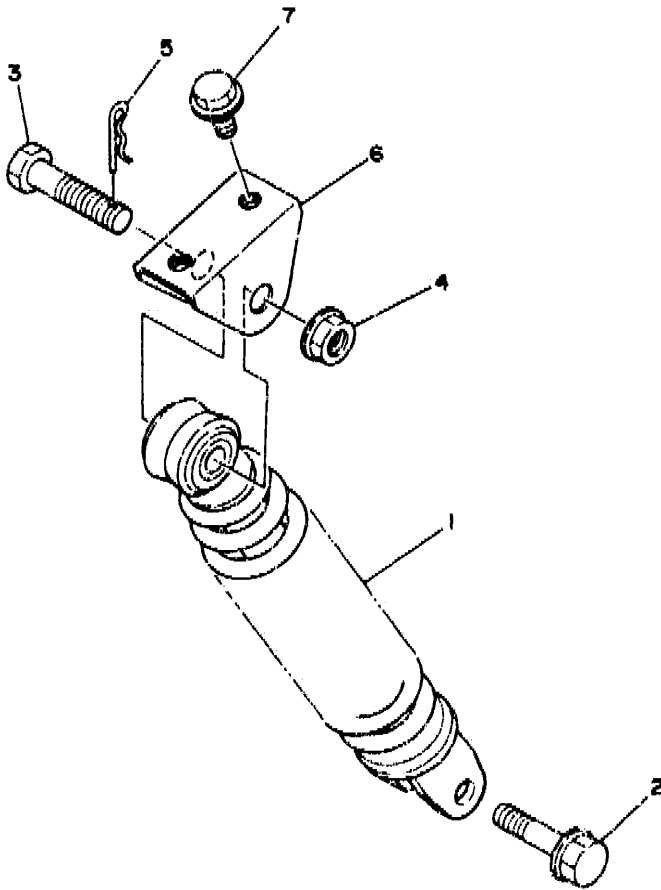

3KJ1010-9160

CA

FIG. 17 FRONT FORK

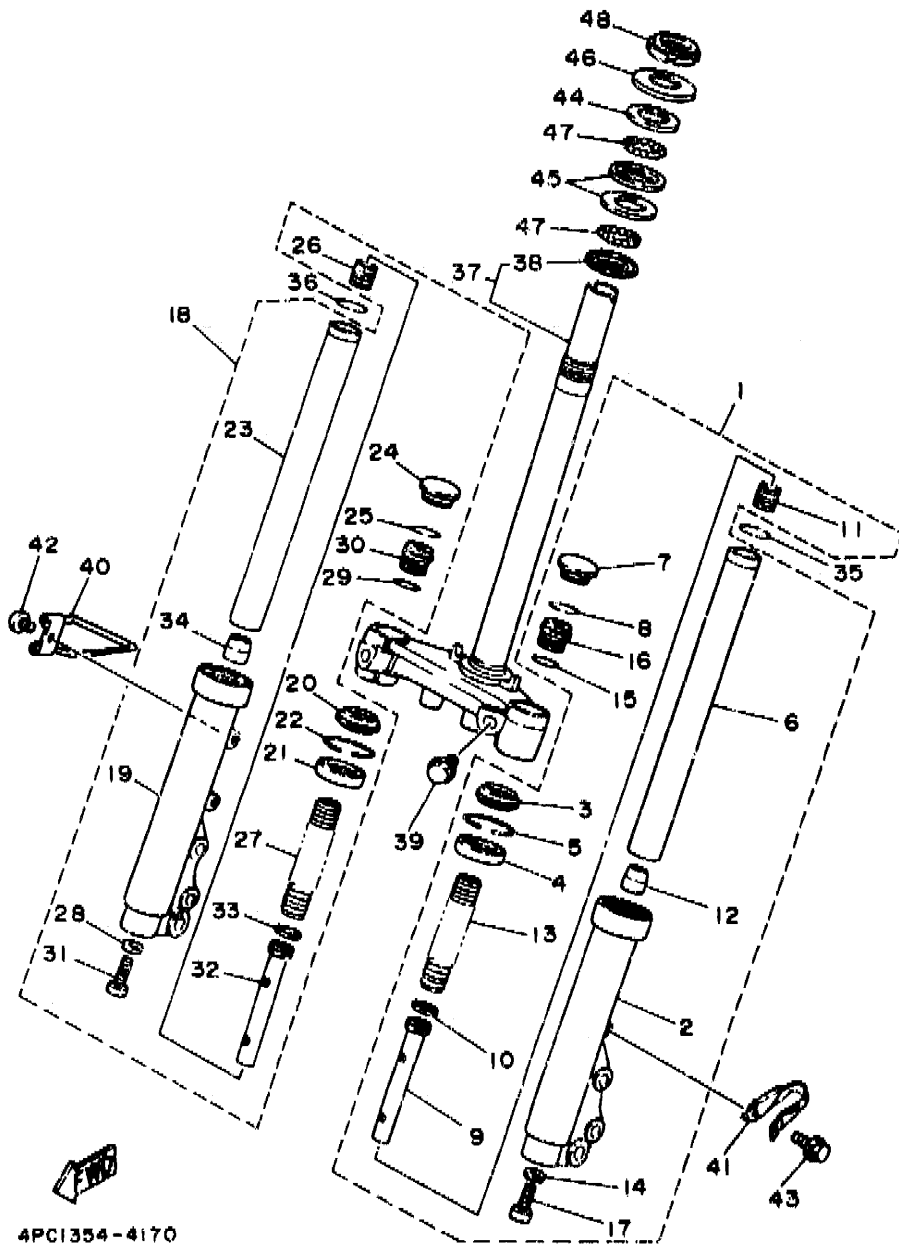

4PC1354-4170

REF. NO.	PART NO.	DESCRIPTION	Q'TY	REMARKS
1	4PC-F3102-P0	FRONT FORK ASSY (L.H)	1	
2	4PC-F3126-P0	.TUBE, OUTER (LEFT)	1	
3	4CU-F3144-00	.SEAL, DUST	1	
4	4CU-F3145-00	.OIL SEAL	1	
5	4CU-F3156-00	.CLIP, OIL SEAL	1	
6	4CU-F3110-00	.INNER TUBE COMP.1	1	
7	4CU-F3154-00	.PLUG, INNER TUBE	1	
8	4CU-F3183-00	.CIRCLIP	1	
9	4CU-F3171-P0	.PISTON, FRONT FORK	1	
10	4CU-F3157-00	.RING, PISTON	1	
11	4CU-F3151-00	.SPRING, REBOUND	1	
12	4CU-F3173-00	.SPINDLE, TAPER	1	
13	4CU-F3141-P0	.SPRING, FRONT FORK	1	
14	4CU-F3165-00	.WASHER, FELT	1	
15	4CU-F3147-00	.O-RING	1	
16	4CU-F3111-00	.BOLT, CAP	1	
17	4CU-F3181-00	.BOLT, HEXAGON SOCKET HEAD	1	
18	4PC-F3103-P0	FRONT FORK ASSY (R.H)	1	
19	4PC-F3136-P0	.TUBE, OUTER (RIGHT)	1	
20	4CU-F3144-00	.SEAL, DUST	1	
21	4CU-F3145-00	.OIL SEAL	1	
22	4CU-F3156-00	.CLIP, OIL SEAL	1	
23	4CU-F3110-00	.INNER TUBE COMP.1	1	
24	4CU-F3154-00	.PLUG, INNER TUBE	1	
25	4CU-F3183-00	.CIRCLIP	1	
26	4CU-F3151-00	.SPRING, REBOUND	1	
27	4PC-F3141-P0	.SPRING, FRONT FORK	1	
28	4CU-F3165-00	.WASHER, FELT	1	

C5

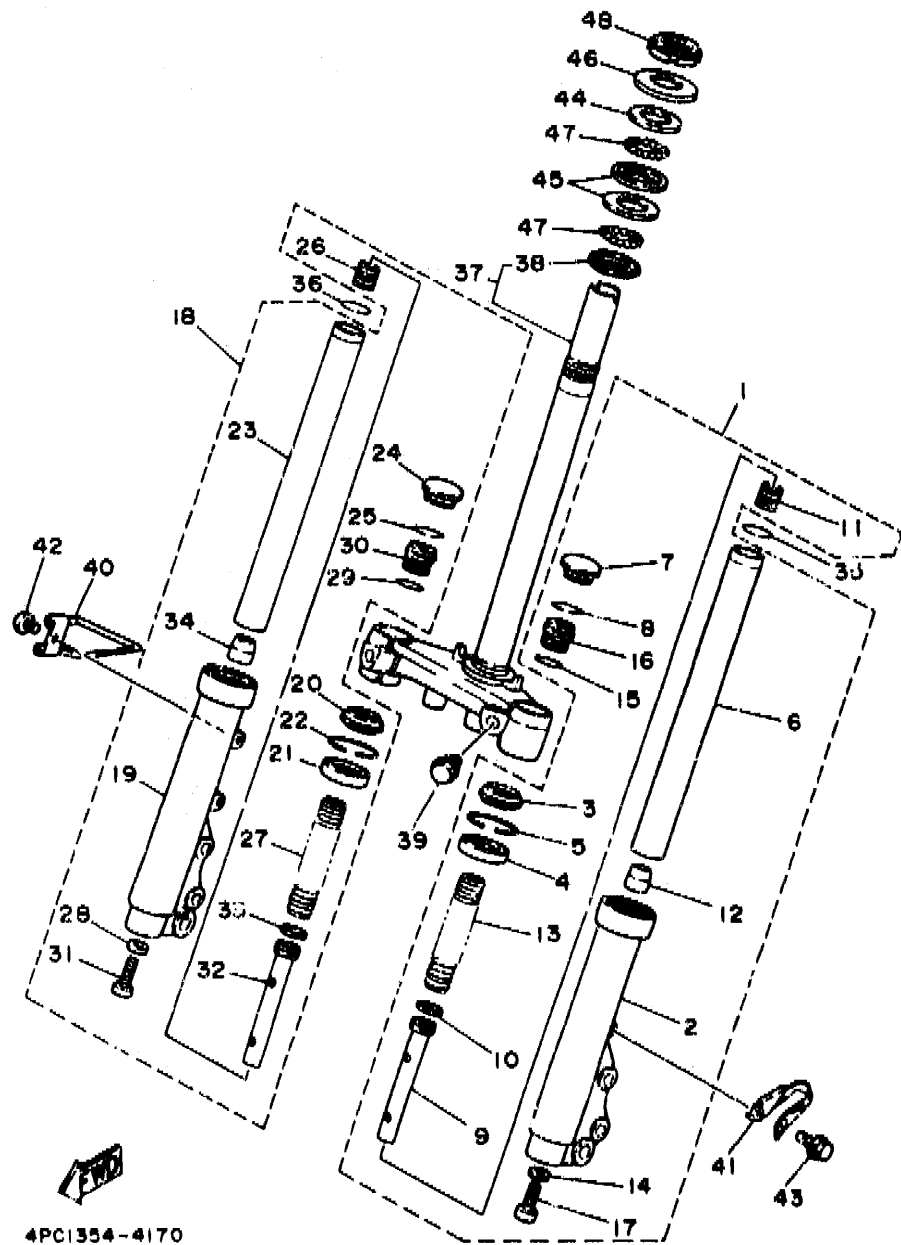

4PC1354-4170

FIG. 17 FRONT FORK

REF. NO.	PART NO.	DESCRIPTION	Q'TY	REMARKS
29	4CU-F3147-00	.O-RING	1	
30	4CU-F3111-00	.BOLT, CAP	1	
31	4CU-F3181-00	.BOLT, HEXAGON SOCKET HEAD	1	
32	4PC-F3171-PO	.PISTON, FRONT FORK	1	
33	4CU-F3157-00	.RING, PISTON	1	
34	4CU-F3173-00	.SPINDLE, TAPER	1	
35	4CU-F3153-00	RING, SNAP	1	
36	4CU-F3153-00	RING, SNAP	1	
37	4PC-F3340-00	UNDER BRACKET COMP.	1	
38	22F-23414-01	.RACE, BALL 4	1	
39	95827-10030	BOLT, FLANGE	2	
40	4PC-F3317-00	HOLDER, CABLE	1	
41	4PC-F5875-00	HOLDER, BRAKE HOSE 1	1	
42	98907-06010	SCREW, BIND	1	
43	95807-06016	BOLT, FLANGE	1	
44	22F-23411-01	RACE, BALL 1	1	
45	22F-23412-01	RACE, BALL 2	2	
46	3VP-23416-00	COVER, BALL RACE 2	1	
47	93503-16010	BALL	44	
48	90179-25033	NUT	2	

C6

FIG. 18 FUEL TANK

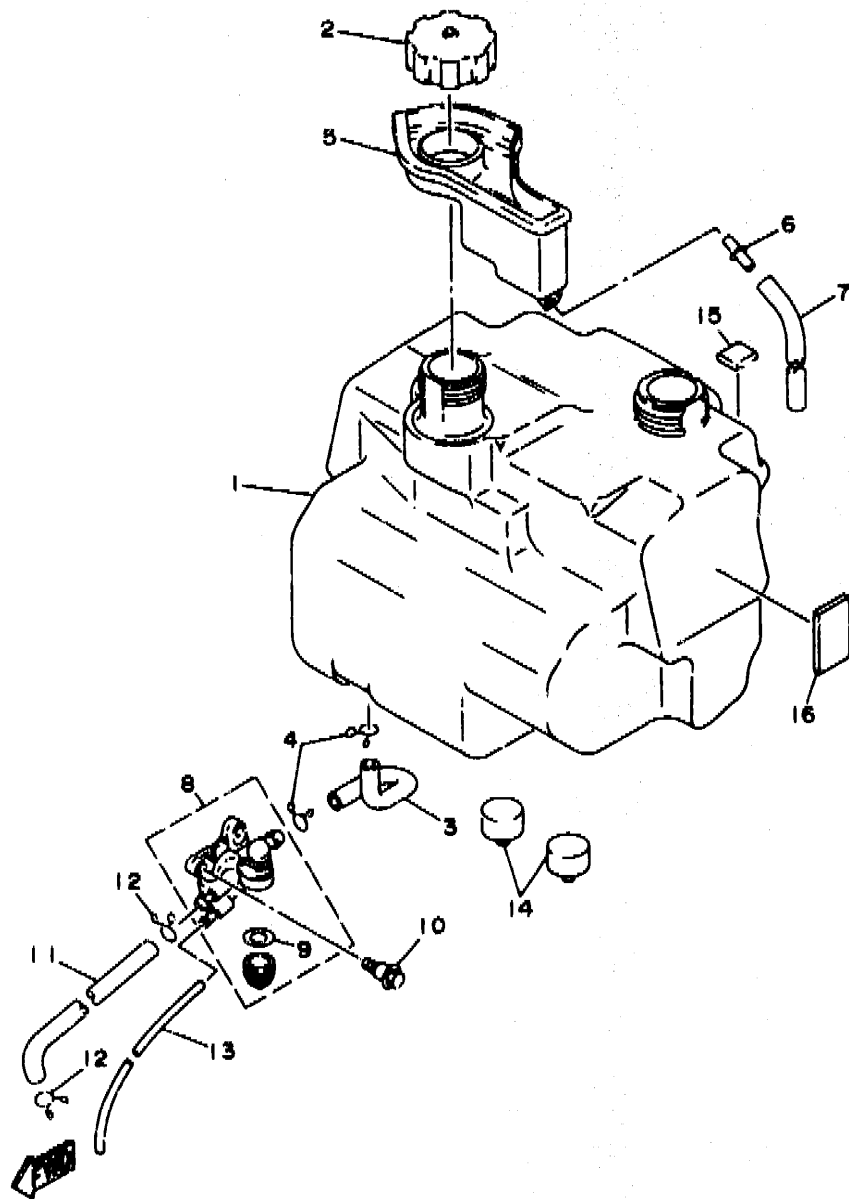

REF. NO.	PART NO.	DESCRIPTION	Q'TY	REMARKS
1	4MJ-F4111-00	TANK, FUEL	1	
2	4MJ-F4610-00	CAP ASSY	1	
3	4MJ-F4312-00	PIPE 2	1	
4	90467-11106	CLIP	2	
5	4MJ-F414A-01	COVER, FILLER	1	
6	90560-06366	SPACER	1	
7	4MJ-F416A-00	HOSE	1	
8	3KJ-24500-01	FUEL COCK ASSY 1	1	
9	4X8-24565-00	.GASKET	1	
10	90109-063F5	BOLT	2	
11	4MJ-F4311-00	PIPE, FUEL 1	1	
12	90467-09006	CLIP	2	
13	90445-07434	HOSE	1	
14	2JW-F7114-00	STOPPER, MAIN STAND	4	
15	2E9-24182-00	DAMPER, LOCATING 2	4	
16	4MJ-F4183-00	DAMPER, LOCATING 3	2	

4MJ1352-4190

FIG. 19 SEAT

REF. NO.	PART NO.	DESCRIPTION	Q'TY	REMARKS
1	4PC-F4730-00	DOUBLE SEAT ASSY	1	UR FOR FRS
	4PC-F4730-10	DOUBLE SEAT ASSY	1	UR FOR SDGC1
2	4MJ-F475M-00	.SEAL	1	
3	4MJ-F473R-00	BOX 1	1	
4	4MJ-F4747-00	DAMPER, SEAT	3	
5	90109-063F1	BOLT	2	
6	4PC-F4780-00	SEAT LOCK ASSY	1	
7	3WG-F4726-00	HINGE, SEAT	1	
8	90241-10015	PIN	1	
9	3VP-24717-00	BOLT, SEAT FITTING	2	
10	90179-05403	NUT	4	
11	90201-086A3	WASHER, PLATE	2	
12	3WG-H2129-00	COVER, BATTERY	1	
13	90167-05041	SCREW, TAPPING	1	

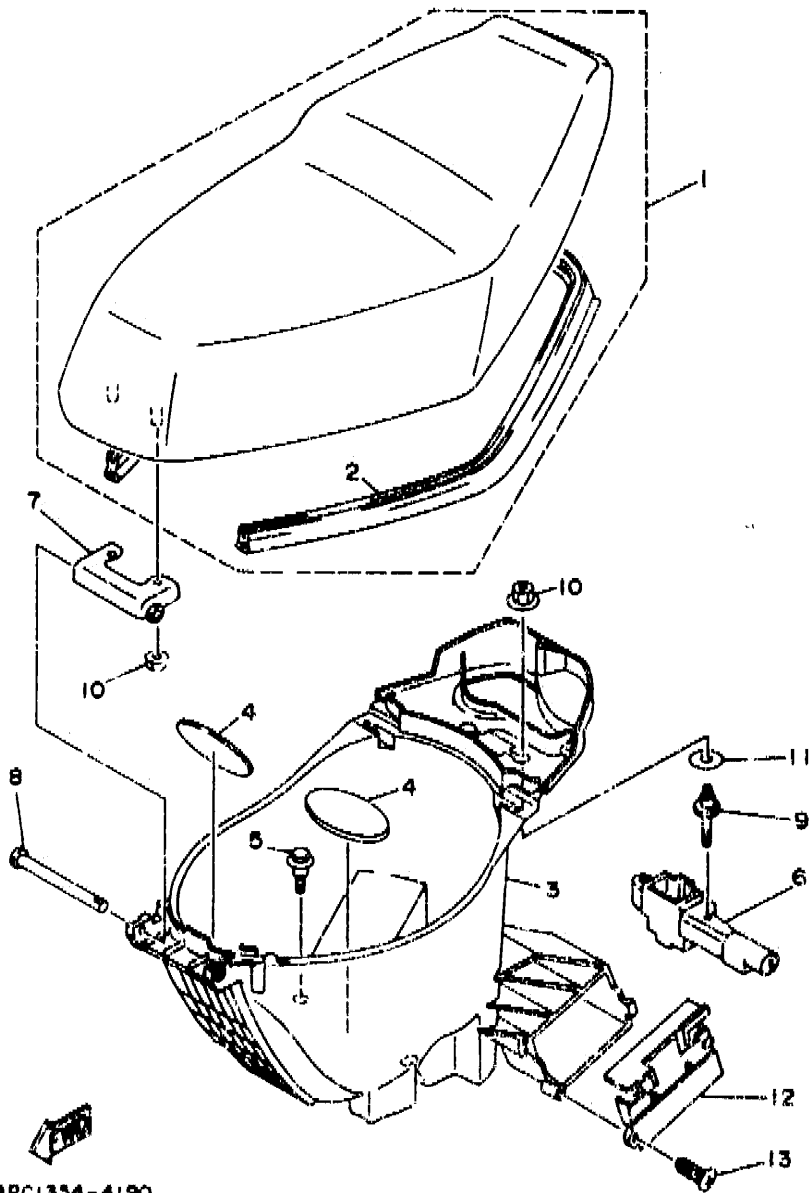

4PC1354-4190

C8

FIG. 20 FRONT WHEEL

REF. NO.	PART NO.	DESCRIPTION	Q'TY	REMARKS
1	4PC-F5168-00-35	CAST WHEEL, FRONT	1	SILVER
2	4KH-F5117-00	SPACER, BEARING	1	
3	4KH-F5115-00	FLANGE, SPACER 1	1	
4	93106-20001	OIL SEAL	1	
5	93306-30003	BEARING (B6300Z)	2	
6	*	TIRE (10G/80-10, PIRELLI SL26)	1	LM (PIRELLI SL26)
7	3VL-F5170-10	AIR VALV. ASSY	1	
8	90185-10154	NUT, SELF-LOCKING	1	
9	4PC-F5181-00	AXLE, WHEEL	1	
10	90387-10079	COLLAR	1	
11	4JC-25190-00	GEAR UNIT ASSY	1	

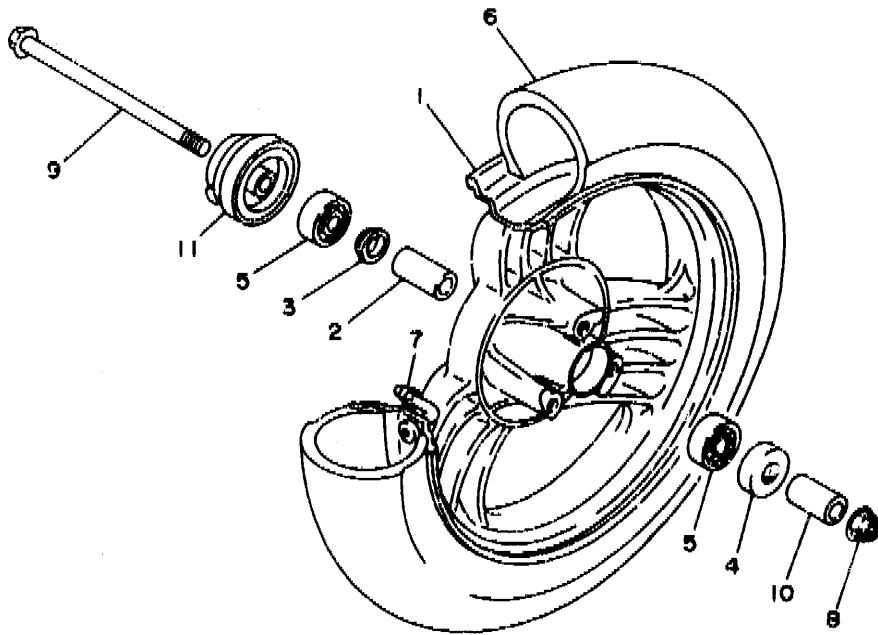

4PC1354-4200

C9

FIG. 21 FRONT BRAKE CALIPER

REF. NO.	PART NO.	DESCRIPTION	Q'TY	REMARKS
1	2NA-25831-00	DISC. BRAKE (RIGHT)	1	
2	90110-10821	BOLT, HEXAGON SOCKET HEAD	3	
3	4CU-F580T-00	CALIPER ASSY (LEFT)	1	
4	4CU-F5824-00	.SCREW, BREED	1	
5	4CU-F5919-00	.SUPPORT, PAD	1	
6	4CU-F5825-00	.CAP	1	
7	4CU-F5811-00	.PAD, CALIPER 2	1	
8	95827-08030	BOLT, FLANGE	2	

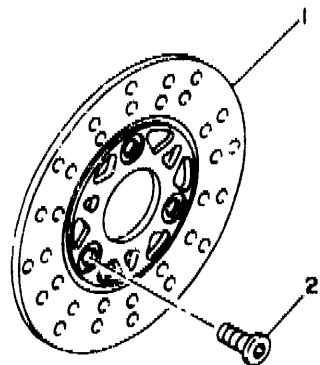
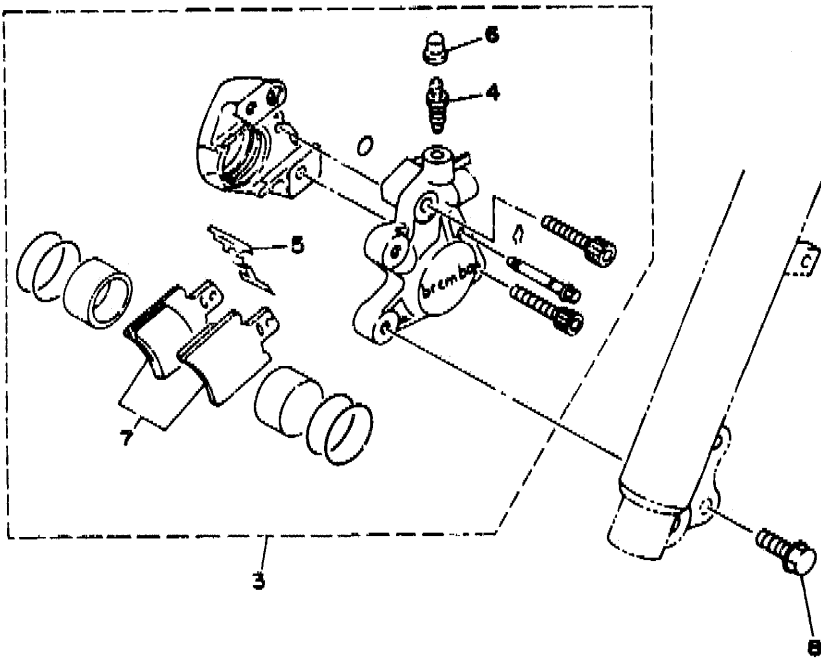

4PC1354-4210

C10

FIG. 22 REAR WHEEL

REF. NO.	PART NO.	DESCRIPTION	Q'TY	REMARKS
1	4PC-F5338-00-35	CAST WHEEL, REAR	1	SILVER
2	*	TIRE (100/80-10, PIRELLI SL26)	1	LM (PIRELLI SL26)
3	3VL-F5170-10	AIR VALVE ASSY	1	
4	4CU-F5326-00	PIN, PIVOT	1	
5	95707-08500	NUT, FLANGE	1	
6	93210-07540	O-RING	1	
7	2JL-W2336-10	BRAKE SHOE SET	1	
8	90506-15260	SPRING, TENSION	2	
9	3KJ-25351-00	CAMSHAFT	1	
10	3WG-F5355-00	LEVER, CAMSHAFT	1	
11	3WG-F513A-00	PLATE, INDICATOR	1	
12	90101-06278	BOLT	1	
13	90201-142M6	WASHER, PLATE	1	
14	90185-14150	NUT, SELF-LOCKING	1	
15	90201-17255	WASHER, PLATE	1	
16	3WG-F5357-00	SPRING, LEVER RETURN	1	

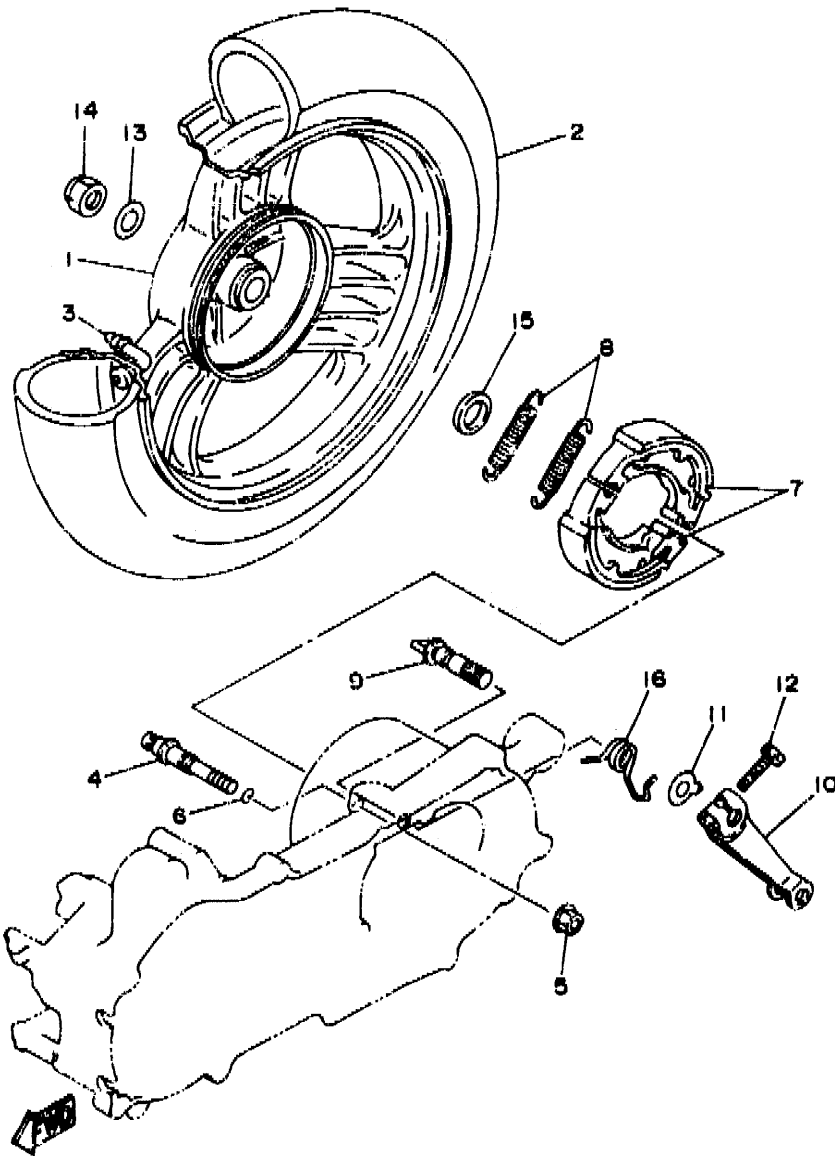

4PC1354-4220

C11

FIG. 23 STEERING HANDLE. CABLE

REF. NO.	PART NO.	DESCRIPTION	Q'TY	REMARKS
1	4PC-F6110-00	HANDLE COMP.	1	
2	90105-10036	BOIT, WASHER BASED	1	
3	90185-10154	NUT, SELF-LOCKING	1	
4	90464-13804	CLAMP	1	
5	3VL-F6241-00	GRIP (LEFT)	1	
6	3VL-F6242-00	GRIP (RIGHT)	1	
7	3WG-F6243-00	TUBE, THROTTLE GUIDE	1	
8	4PC-F6311-00	CABLE, THROTTLE 1	1	
9	3WG-F6312-00	CABLE, THROTTLE 2	1	
10	3WG-F6329-00	CAP, RUBBER	1	
11	98507-05010	SCREW, PAN HEAD	1	
12	4PC-F6351-00	CABLE, BRAKE	1	
13	3WG-F6393-00	HOLDER	1	
14	90179-06411	NUT	1	
15	90249-12008	PIN	1	

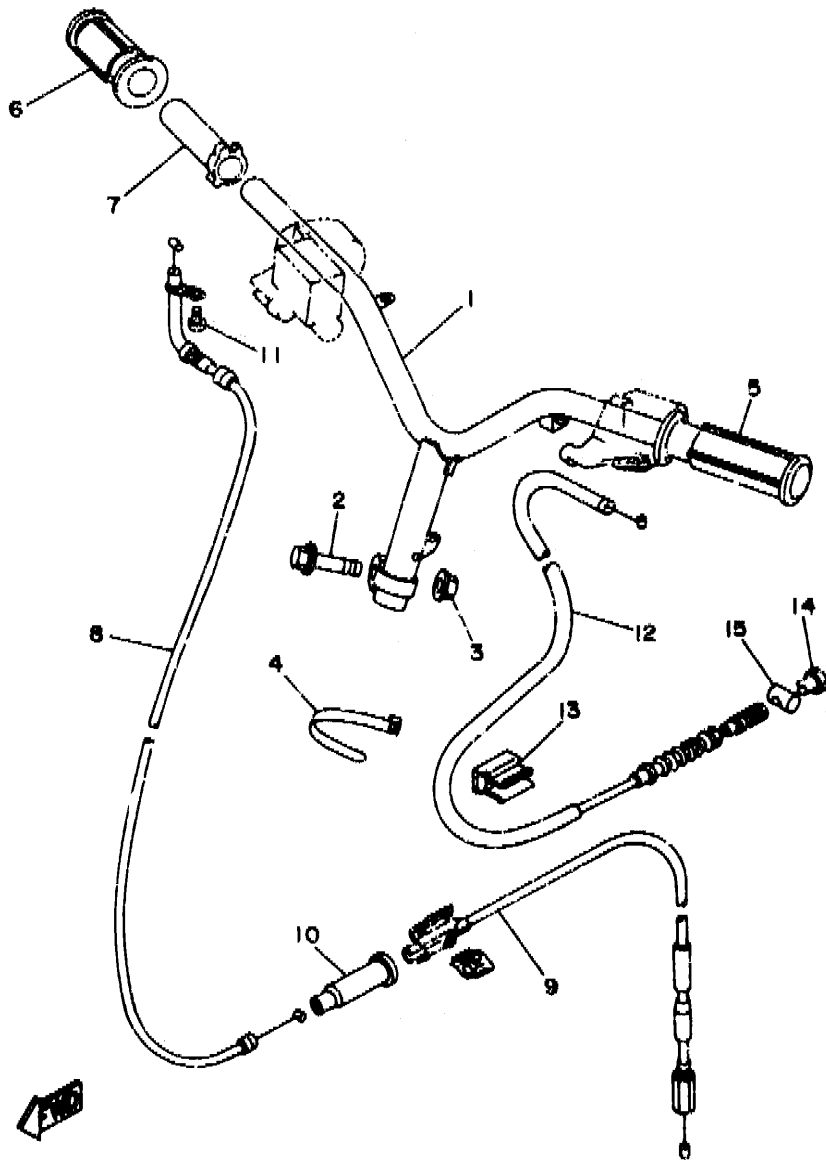

4PC/354-4230

C12

FIG. 24 FRONT MASTER CYLINDER

REF. NO.	PART NO.	DESCRIPTION	Q'TY	REMARKS
1	3RY-25870-02	MASTER CYLINDER SUB ASSY	1	
2	3RW-W0641-02	.CYLINDER KIT, MASTER	1	
3	3RW-25854-00	.DIAPHRAGM, RESERVOIR	1	
4	3RW-25852-00	.CAP, RESERVOIR	1	
5	98706-04012	.SCREW, FLAT HEAD	2	
6	56A-25867-00	BRACKET, MASTER CYLINDER	1	
7	91317-06025	BOLT	2	
8	4PC-F5872-00	HOSE, BRAKE 1	1	
9	2RN-F5877-00	BOLT, OIL 1	2	
10	90201-10118	WASHER, PLATE	4	

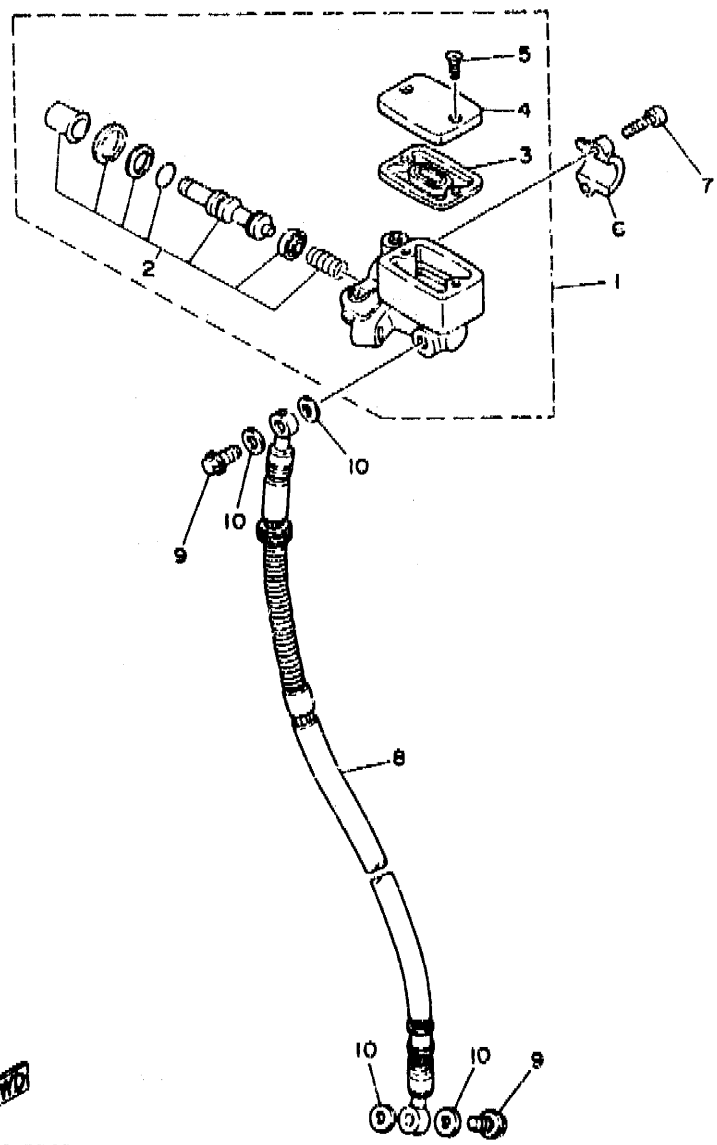



39F1414-9240

C13

FIG. 25 STAND, FOOTREST

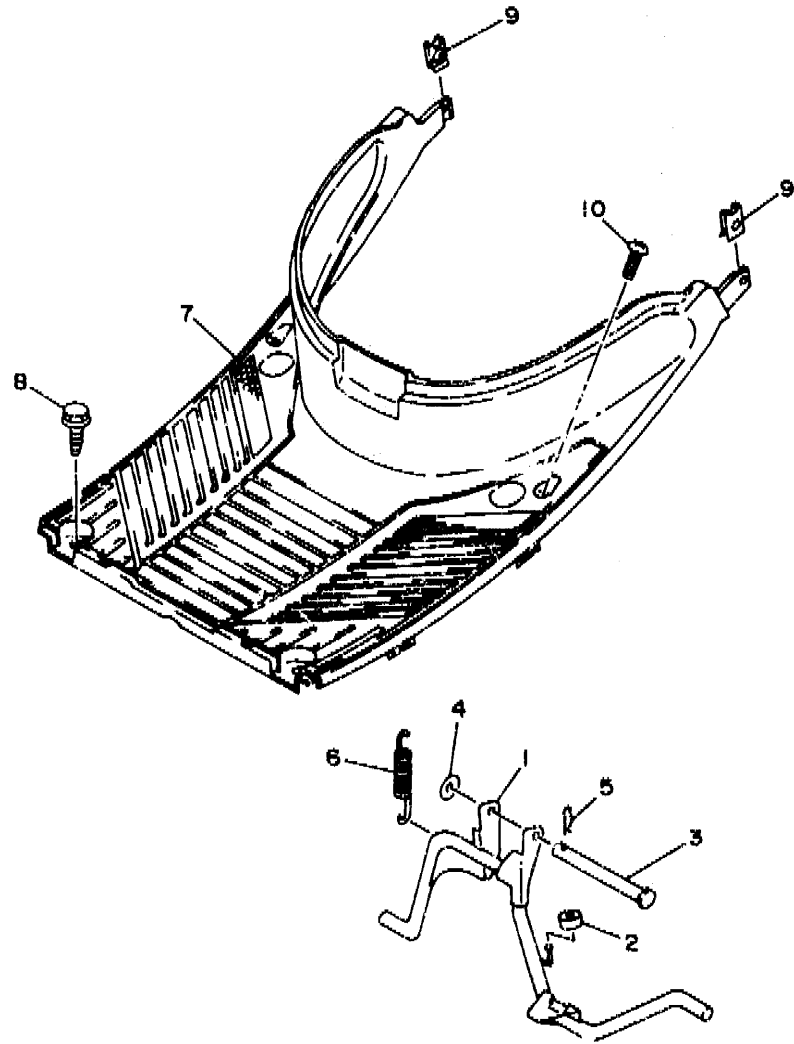
REF. NO.	PART NO.	DESCRIPTION	Q'TY	REMARKS
1	4CX-F7111-00	STAND, MAIN	1	
2	90387-064A4	COLLAR	1	
3	90240-10137	PIN, CLEVIS	1	
4	90202-10120	WASHER, PLATE	1	
5	90468-12006	CLIP	1	
6	90506-32464	SPRING, TENSION	1	
7	4MJ-F7481-00	BOARD, FOOTREST	1	
8	90119-06118	BOLT, WITH WASHER	4	
9	90183-05042	NUT, SPRING	2	
10	97707-50016	SCREW, TAPPING	2	



4MJ1352-4240

C14

FIG. 26 LEG SHIELD

REF. NO.	PART NO.	DESCRIPTION	Q'TY	REMARKS
1	4MJ-F8311-00	LEG SHIELD 1	1	
2	4MJ-F8371-00	DAMPER	1	
3	35R-21796-00	HINGE	2	
4	97707-10512	SCREW, TAPPING	2	
5	3VR-28313-00	LID	1	LOW GLOSS GRAY
6	4PC-F1780-00	LOCK ASSY	1	
7	90159-06835	SCREW, WITH WASHER	1	
8	4MJ-F834V-00	PROTECTOR 1	1	
9	97707-50016	SCREW, TAPPING	4	
10	97707-50016	SCREW, TAPPING	2	
11	3WG-F8349-60	CAP	1	
12	4MJ-F8385-00	COVER, LOWER	1	UR FOR FRS
	4MJ-F8385-10	COVER, LOWER	1	UR FOR SDGC1
13	3VP-21535-00	NUT 1	2	

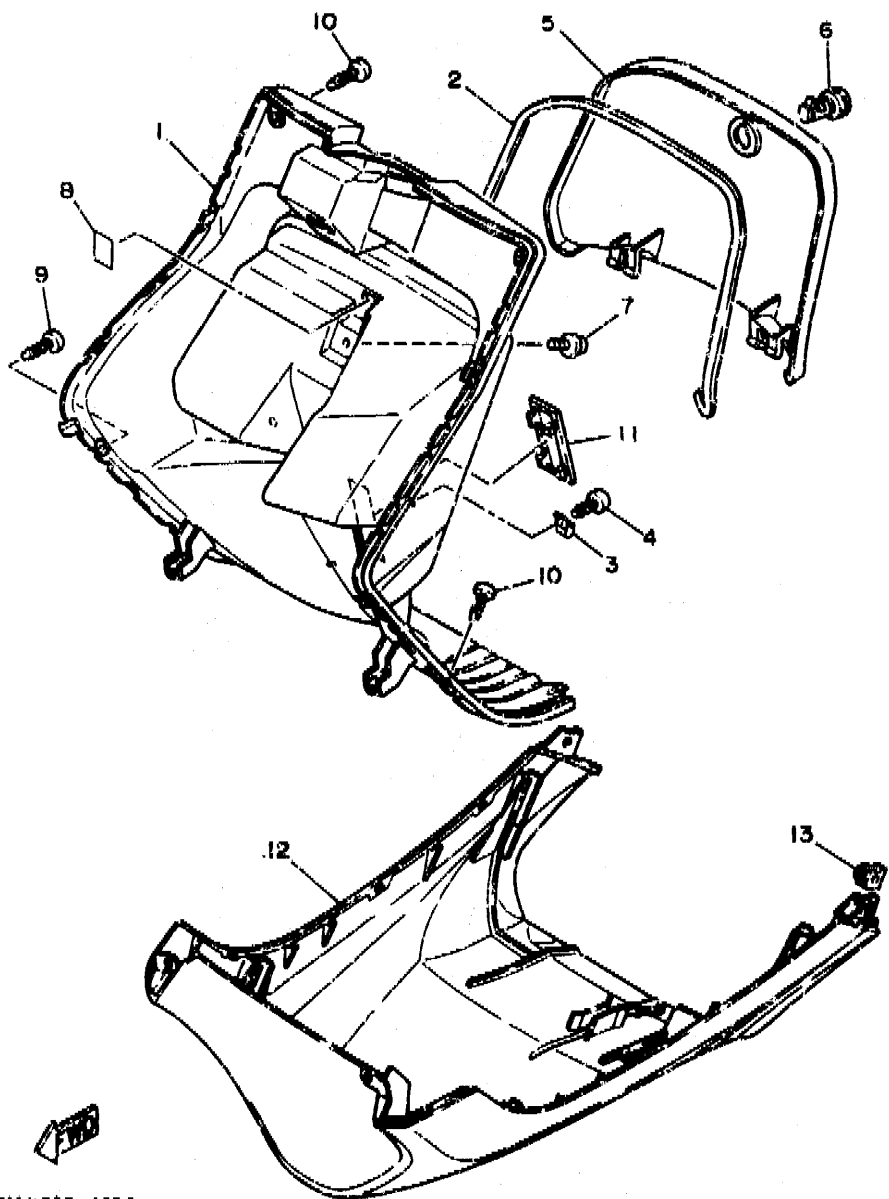

4MJ:352-4250

C15

CONTENTS

ENGINE

Cylinder Head	B2
Crankshaft, Piston	B3
Air Shroud, Fan	B4
Oil Pump	B5
Intake	B6
Carburetor	B7
Exhaust	B8
Crankcase	B9
Starter	B10
Clutch	B11~B12
Transmission	B13

Generator	D3
Meter	D4
Headlight	D5
Taillight	D6
Handle Switch, Lever	D7
Electrical 1	D8
Electrical 2	D9

INDEX

Numerical Index	M1~M2
-----------------------	-------

CHASSIS

Frame	B14
Fender	B15
Side Cover	C2
Oil Tank	C3
Rear Suspension	C4
Front Fork	C5~C6
Fuel Tank	C7
Seat	C8
Front Wheel	C9
Front Brake Caliper	C10
Rear Wheel	C11
Steering Handle, Cable	C12
Front Master Cylinder	C13
Stand, Footrest	C14
Leg Shield	C15
Cowling 1	D2

CONTENTS

ENGINE

Cylinder Head	B2
Crankshaft, Piston	B3
Air Shroud, Fan	B4
Oil Pump	B5
Intake	B6
Carburetor	B7
Exhaust	B8
Crankcase	B9
Starter	B10
Clutch	B11~B12
Transmission	B13

Generator	D3
Meter	D4
Headlight	D5
Taillight	D6
Handle Switch, Lever	D7
Electrical 1	D8
Electrical 2	D9

INDEX

Numerical Index	M1~M2
-----------------------	-------

CHASSIS

Frame	B14
Fender	B15
Side Cover	C2
Oil Tank	C3
Rear Suspension	C4
Front Fork	C5~C6
Fuel Tank	C7
Seat	C8
Front Wheel	C9
Front Brake Caliper	C10
Rear Wheel	C11
Steering Handle, Cable	C12
Front Master Cylinder	C13
Stand, Footrest	C14
Leg Shield	C15
Cowling 1	D2

FIG. 27 COUPLING 1

REF. NO.	PART NO.	DESCRIPTION	QTY	REMARKS
1	4PC-F6213-00-P1	COVER, UPPER	1	UR SPANISH DARK GREEN COCKTAIL 1
	4PC-F6213-00-9G	COVER, UPPER	1	UR FROST SILVER
2	4MJ-F639G-00	SEAL	1	
3	4MJ-F6215-00	COVER, LOWER	1	UR GRAY
	4MJ-F6215-10	COVER, LOWER	1	UR BLACK
4	97707-50016	SCREW, TAPPING	4	
5	90159-05121	SCREW, WITH WASHER	1	
6	4PC-F415E-00	LABEL, CAUTION	1	
7	4MJ-F6280-00	REAR VIEW MIRROR ASSY (LEFT)	1	
8	90338-0701B	PLUG	1	
9	90464-13804	CLAMP	1	

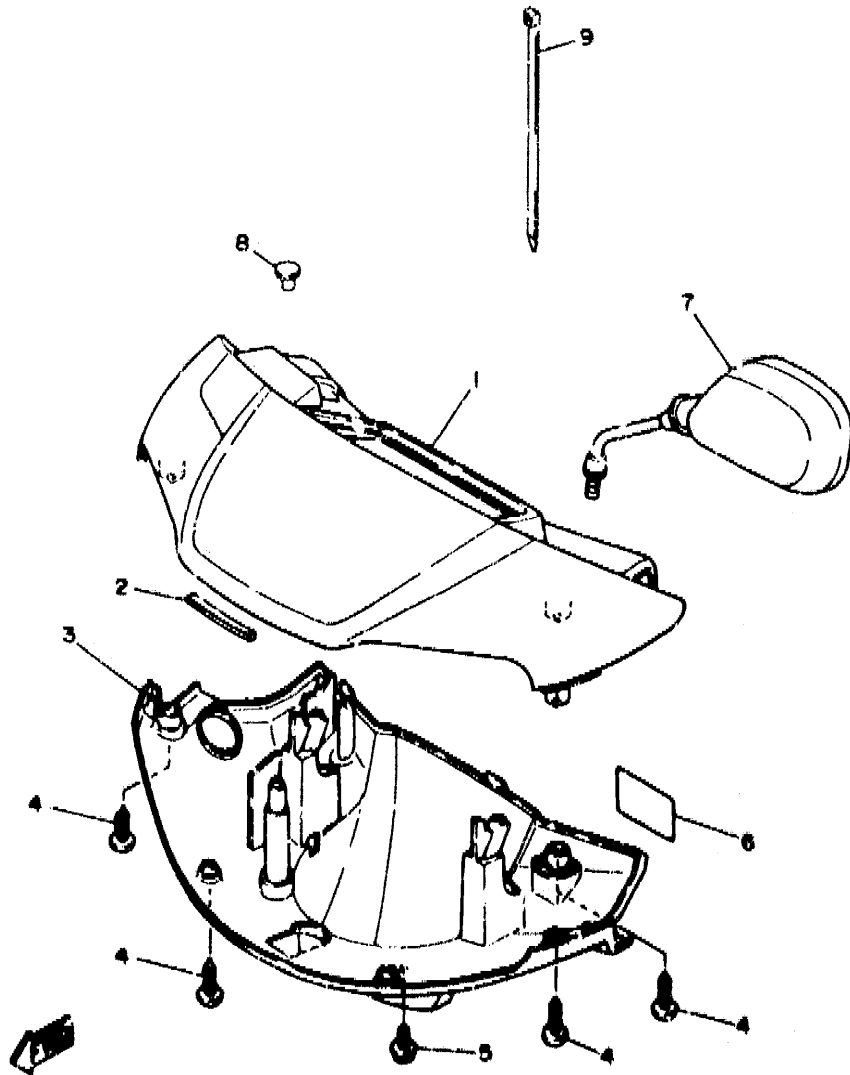

4MJ1352-4260

D2

FIG. 28 GENERATOR

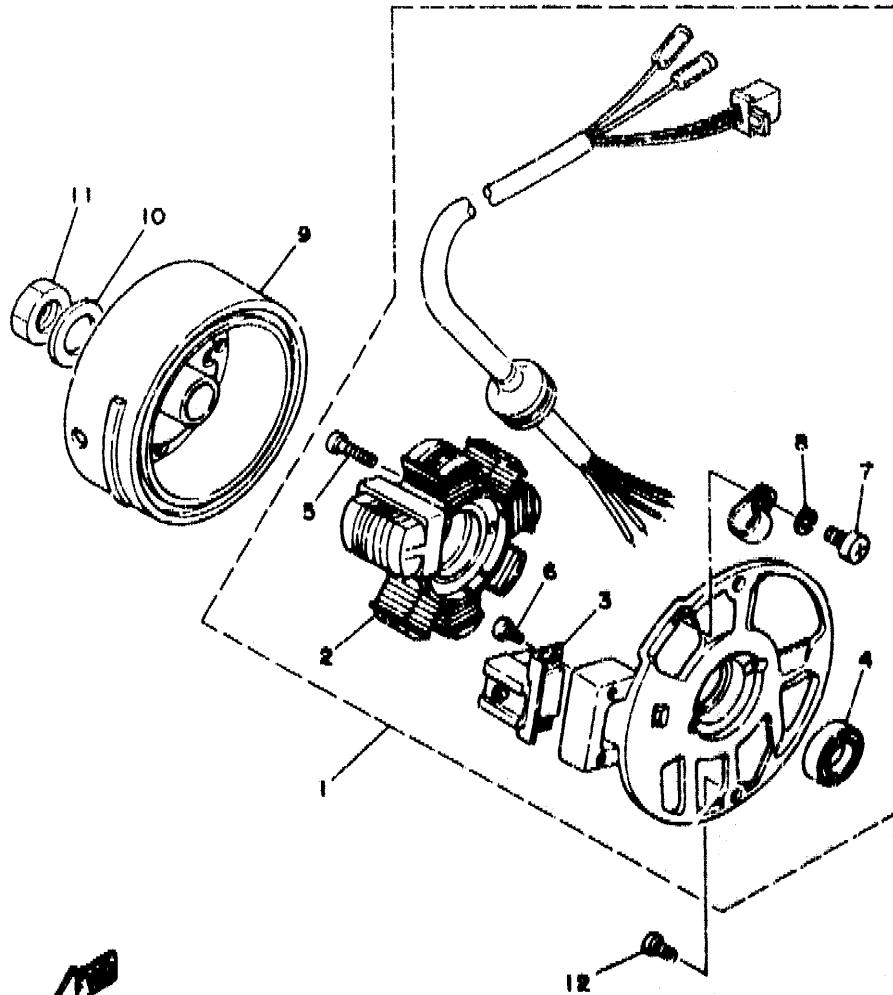

REF. NO.	PART NO.	DESCRIPTION	Q'TY	REMARKS
1	3KJ-85560-C0	BASE ASSY	1	
2	2JA-81403-M0	.STATORCOMP.	1	
3	2JA-85580-M0	.COIL, PULSER	1	
4	93104-19097	.OIL SEAL	1	
5	98511-05020	.SCREW, PAN HEAD	2	
6	98507-05010	.SCREW, PAN HEAD	2	
7	98501-04006	.SCREW, PAN HEAD	1	
8	92901-04100	.WASHER, SPRING	1	
9	2JA-85550-00	ROTOR ASSY	1	
10	92907-10600	WASHER	1	
11	90176-10219	NUT	1	
12	98507-06016	SCREW, PAN HEAD	2	

3KJ1010-9280

D3

FIG. 29 METER

REF. NO.	PART NO.	DESCRIPTION	Q'TY	REMARKS
1	4PC-H3510-00	SPEEDOMETER ASSY	1	
2	4MJ-H3516-00	.BULB	1	
3	4MJ-H3517-00	.BULB	2	
4	4MJ-H3520-00	.SOCKET CORD ASSY	1	
5	4MJ-H366W-00	.NUT	3	
6	97707-50016	SCREW, TAPPING	3	
7	3WG-H3550-R1	SPEEDOMETER CABLE ASSY	1	

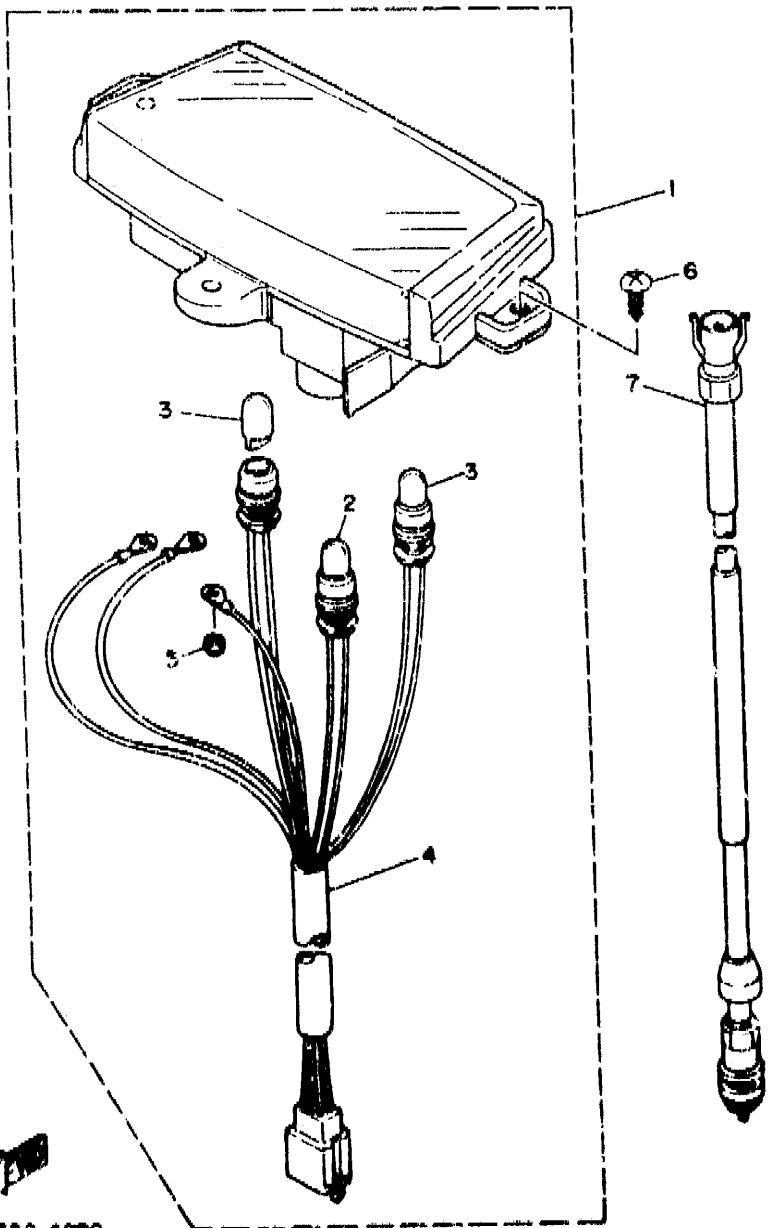

4MJ1352-4200

D4

FIG. 30 HEADLIGHT

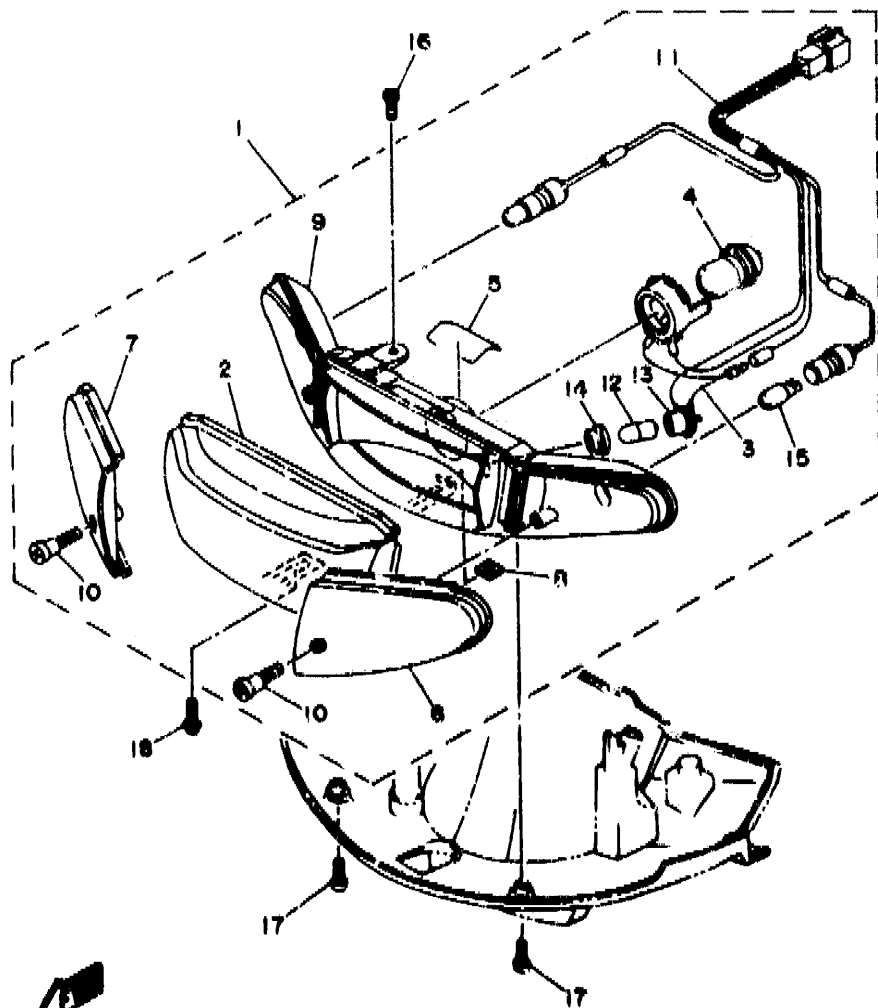

REF. NO.	PART NO.	DESCRIPTION	Q'TY	REMARKS
1	4PC-H4300-00	HEADLIGHT ASSY	1	FOR BLACK COLOR
2	4PC-H4321-00	.LENS ASSY	1	
3	4PC-H4312-00	.HOLDER, SOCKET	1	
4	4PC-H4314-00	.BULB, HEADLIGHT	1	
5	3WG-H4324-00	.SPRING, REFLECTOR	1	
6	4PC-H3312-00	.LENS, FLASHER	1	UR FOR BLACK COLOR
	4MJ-H3312-00	.LENS, FLASHER	1	UR FOR AMBER COLOR
7	4PC-H3322-00	.LENS, FLASHER 2	1	UR FOR BLACK COLOR
	4MJ-H3322-00	.LENS, FLASHER 2	1	UR FOR AMBER COLOR
8	4MJ-H4317-00	.NUT	1	
9	4MJ-H4311-00	.BODY, HEADLIGHT	1	
10	4MJ-H4337-00	.BOLT, SPECIAL	2	
11	4PC-H4359-00	.CORD, HEADLIGHT	1	
12	4CX-H4347-00	.BULB (12V-4W)	1	
13	4CX-H4346-00	.SOCKET, PILOT LIGHT	1	
14	4CX-H4352-00	.GROMMET	1	
15	1YT-83311-00	.BULB (12V-10W)	2	
16	97707-50016	SCREW, TAPPING	1	
17	97707-50025	SCREW, TAPPING	2	
18	90159-05155	SCREW, WITH WASHER	1	

4PC1364-4300

D3

FIG. 31 TAILLIGHT

REF. NO.	PART NO.	DESCRIPTION	Q'TY	REMARKS
1	4PC-H4700-00	TAILLIGHT ASSY	1	FOR BLACK COLOR
2	4MJ-H4721-00	.LENS, TAILLIGHT	1	
3	4PC-H3332-00	.LENS, FLASHER	1	UR FOR BLACK COLOR
	4MJ-H3332-00	.LENS, FLASHER	1	UR FOR AMBER COLOR
4	4PC-H3342-00	.LENS, FLASHER 2	1	UR FOR BLACK COLOR
	4MJ-H3342-00	.LENS, FLASHER 2	1	UR FOR AMBER COLOR
5	97707-40620	.SCREW, TAPPING	2	
6	4MJ-H4743-00	.LENS, LICENCE LIGHT	1	
7	31L-84714-00	.BULB, TAILLIGHT (12V-21/5W)	1	
8	1YT-83311-00	.BULB(12V-10W)	2	
9	3VP-84725-00	.WASHER, SPECIAL	2	
10	90119-06043	BOLT, WITH WASHER	2	
11	97707-50016	SCREW, TAPPING	2	
12	90183-05042	NUT, SPRING	2	

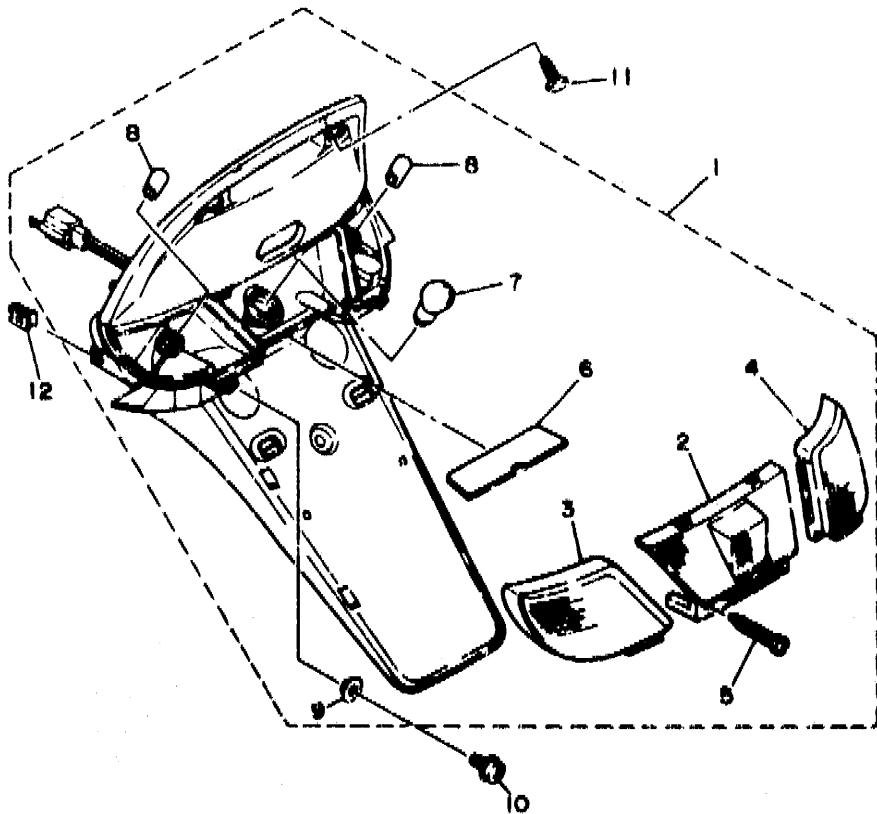

4MJ1352-4300

D6

FIG. 32 HANDLE SWITCH, LEVER

REF. NO.	PART NO.	DESCRIPTION	Q'TY	REMARKS
1	4KH-H2910-00	LEVER HOLDER ASSY (LEFT)	1	
2	4KH-H3912-00	.LEVER 1	1	
3	3VL-H3915-00	.SCREW, LEVER FITTING	1	
4	3VL-H3916-00	.NUT, LEVER FITTING	1	
5	3VL-F636A-00	.END	1	
6	3VL-H3945-00	.BOLT, LEVER	2	
7	4KH-H3962-00	.SPRING	1	
8	3VL-H3980-00	FRONT STOP SWITCH ASSY	1	
9	3VL-H3976-10	SWITCH, HANDLE 1	1	
10	4KH-H3975-10	SWITCH, HANDLE 2	1	
11	4CU-H3987-00	CASE, SWITCH LOWER	1	
12	3VL-H3945-00	.BOLT, LEVER	2	
13	4CU-83980-00	FRONT STOP SWITCH ASSY	1	
14	2NA-83922-01	LEVER 2	1	
15	90109-06577	BOLT	1	
16	95607-06100	NUT, U	1	
17	90501-10312	SPRING, COMPRESSION	1	

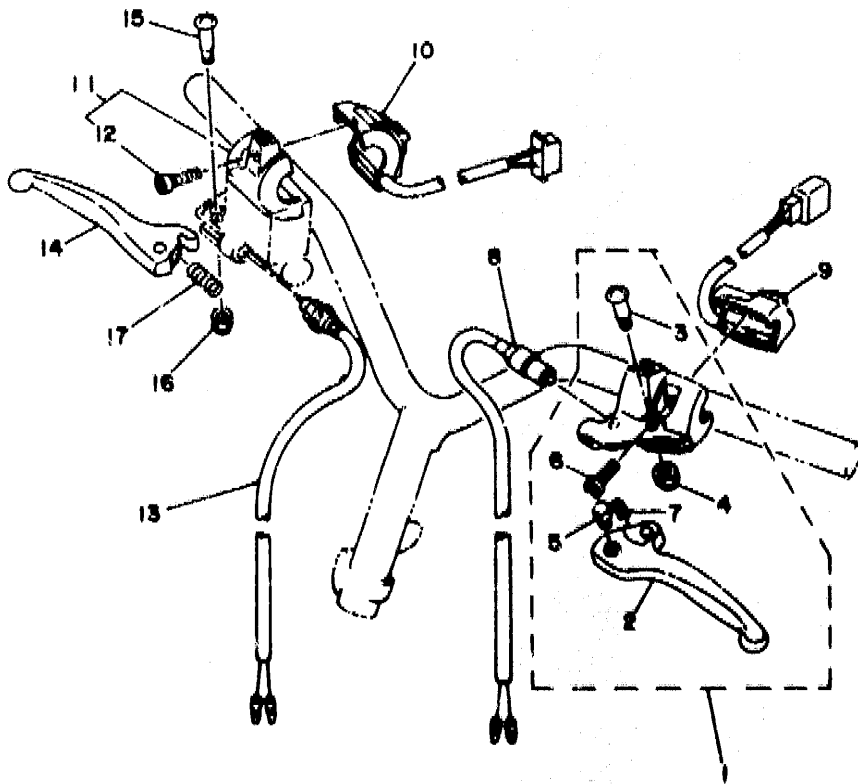

4PC1304-4320

D7

FIG. 33 ELECTRICAL 1

REF. NO.	PART NO.	DESCRIPTION	Q'TY	REMARKS
1	3KJ-81960-11	RECTIFIER & REGULATOR ASSY	1	
2	95027-06016	BOLT, FLANGE	1	
3	4PC-H2501-00	MAIN SWITCH STEERING LOCK	1	
4	4MJ-H2552-00	.CAP. SWITCH	1	
5	90149-06250	SCREW	2	
6	4MJ-H3350-00	FLASHER RELAY ASSY	1	
7	3WW-83371-01	HORN	1	
8	90507-06010	SCREW, PAN HEAD	1	

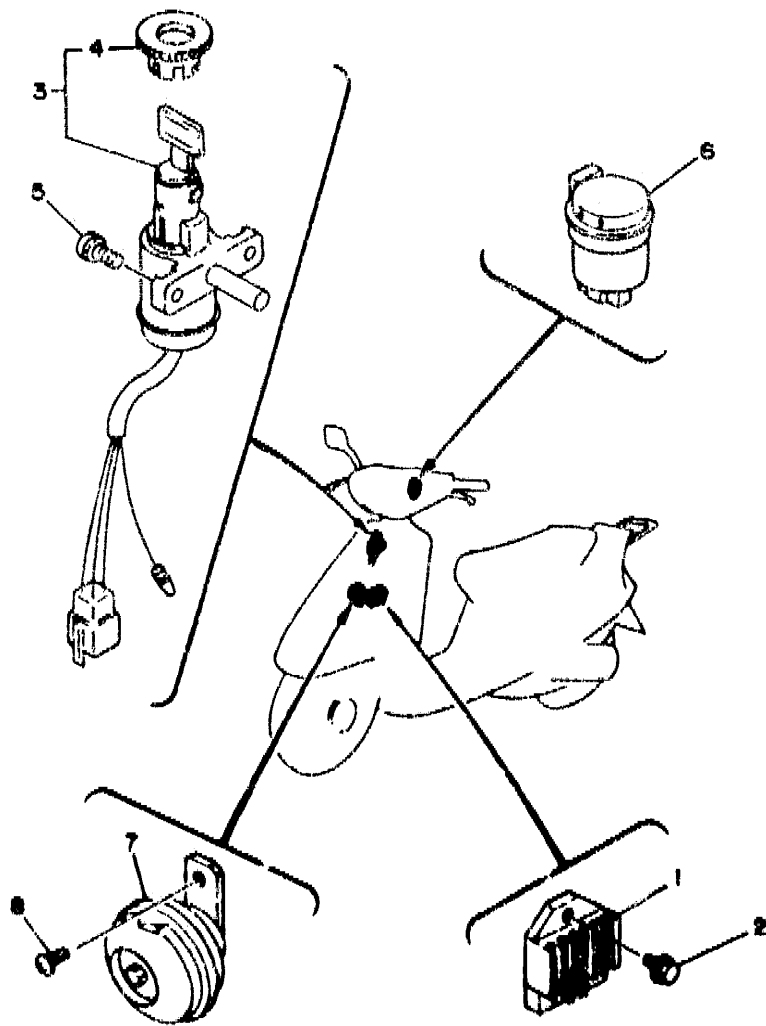

4MJ1352-4320

De

FIG. 34 ELECTRICAL 2

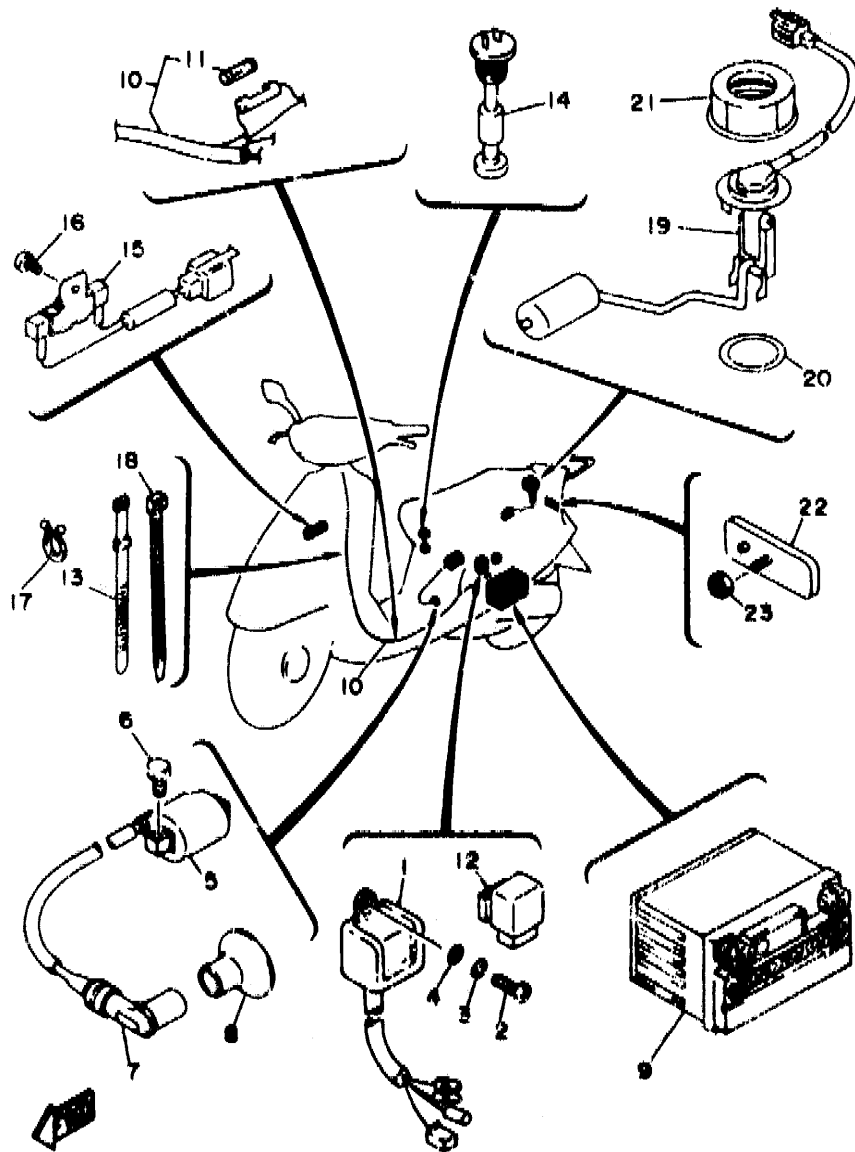

4PC1354-4340

REF. NO.	PART NO.	DESCRIPTION	Q'TY	REMARKS
1	3KJ-85540-01	C.D.I. UNIT ASSY	1	
2	98507-06020	SCREW, PAN HEAD	1	
3	92907-06100	WASHER	1	
4	92907-06600	WASHER	1	
5	3KJ-82310-01	IGNITION COIL ASSY	1	
6	97007-06016	BOLT	2	
7	3WG-H2370-10	PLUG CAP ASSY	1	
8	3WG-H2372-00	SEAL, PLUG CAP	1	
9	3UC-82100-10	BATTERY ASSY (YT4L-BS 12V-3A)	1	
10	4PC-H2590-00	WIRE HARNESS ASSY	1	
11	3WG-H2151-00	.FUSE	1	
12	29U-81950-93	RELAY ASSY	1	
13	5T8-H3936-10	BAND, SWITCH CORD	4	
14	3VL-H5720-10	OIL LEVEL GAUGE ASSY	1	
15	2JA-85370-00	RESISTOR ASSY	1	
16	98507-06010	SCREW, PAN HEAD	1	
17	90465-18147	CLAMP	1	
18	90464-13804	CLAMP	1	
19	4MJ-85752-00	SENDER UNIT ASSY, FUEL METER	1	
20	53L-85753-00	GASKET, SENDER UNIT	1	
21	53L-24261-00	HOUSING, FUEL METER	1	
22	4BA-H5130-00	REAR REFLECTOR ASSY	1	
23	95707-05500	NUT, FLANGE	1	



CONTENTS

ENGINE

Cylinder Head	B2
Crankshaft, Piston	B3
Air Shroud, Fan	B4
Oil Pump	B5
Intake	B6
Carburetor	B7
Exhaust	B8
Crankcase	B9
Starter	B10
Clutch	B11~B12
Transmission	B13

Generator	D3
Meter	D4
Headlight	D5
Taillight	D6
Handle Switch, Lever	D7
Electrical 1	D8
Electrical 2	D9

INDEX

Numerical Index	M1~M2
-----------------------	-------

CHASSIS

Frame	B14
Fender	B15
Side Cover	C2
Oil Tank	C3
Rear Suspension	C4
Front Fork	C5~C6
Fuel Tank	C7
Seat	C8
Front Wheel	C9
Front Brake Caliper	C10
Rear Wheel	C11
Steering Handle, Cable	C12
Front Master Cylinder	C13
Stand, Footrest	C14
Leg Shield	C15
Cowling 1	D2

NUMERICAL INDEX

PART NO.	GRID NO.	PART NO.	GRID NO.	PART NO.	GRID NO.	PART NO.	GRID NO.	PART NO.	GRID NO.	PART NO.	GRID NO.
4CU-E1111-00	B-2	4CU-E7420-00	B-13	4CU-F3144-00	C-5	4PC-F5181-00	C-9	4MJ-H3312-00	D-5	4PC-X1711-00-9G	C-2
4EF-E1181-00	B-2	3VL-E7611-00	B-11	4CU-F3145-00	C-5	4CU-F5326-00	C-11	4PC-H3312-00	D-5	3AA-13100-02	B-5
4CU-E1311-00	B-2	4CU-E7620-00	B-11			4PC-F5338-00-35	C-11	4MJ-H3322-00	D-5	3AA-13124-00	B-5
4CU-E1351-00	B-2	3VL-E7623-00	B-11	4CU-F3147-00	C-5	3WG-F5355-00	C-11	4PC-H3322-00	D-5	2GM-13178-00	B-5
4CU-E1400-00	B-3	4CU-E7632-00	B-11			3WG-F5357-00	C-11	4MJ-H3332-00	D-6	3WF-13185-00	B-5
3VL-E1610-00	B-3	4EF-E7654-00	B-12	4CU-F3151-00	C-5	4CU-F580T-00	C-10	4PC-H3332-00	D-6	1YU-13187-00	B-5
3VL-E1610-20	B-3	4PC-F1110-00	B-14			4CU-F5811-00	C-10	4MJ-H3342-00	D-6	1YU-13473-00	B-5
3VL-E1631-00-96	B-3	4MJ-F117M-00	B-14	4CU-F3153-00	C-6	4CU-F5824-00	C-10	4PC-H3342-00	D-6	1YU-13516-00	B-5
3VL-E1633-00	B-3	4MJ-F1232-00	B-14			4CU-F5825-00	C-10	4MJ-H3350-00	D-8	1YU-13577-00	B-5
3VL-E1636-00	B-3	3WG-F1381-00	C-4	4CU-F3154-00	C-5	4PC-F5872-00	C-13	4PC-H3510-00	D-4	3KJ-1410A-10	B-7
4CU-E2611-00	B-4	3WG-F139X-00	B-14			4PC-F5873-00	C-6	4MJ-H3516-00	D-4	3YJ-14103-00	B-7
4CU-E2651-00	B-4	3WG-F1410-00	B-14	4CU-F3156-00	C-5	2RN-F5877-00	C-5	4MJ-H3517-00	D-4	14T-14104-00	B-7
4CU-E2653-00	B-4	3WG-F1481-00	B-14			4CU-F5919-00	C-10	4MJ-H3520-00	D-4	4JP-14104-00	B-7
4CU-E2658-00	B-4	3WG-F1481-10	B-14	4CU-F3157-00	C-5	4PC-F6110-00	C-12	3WG-H3550-R1	D-4	1HV-14147-00	B-7
4EE-E3555-00	B-5	4PC-F1552-00	B-15			4PC-F6213-00-P1	D-2	4MJ-H365W-00	D-4	288-14161-00	B-7
4CU-E3610-00	B-6	3WG-F1553-00	B-15	4CU-F3165-00	C-5	4PC-F6213-00-9G	D-2	4KH-H3912-00	D-7	4FK-14301-15	B-7
4CU-E3613-00	B-6	4PC-F1571-00	B-15			4MJ-F6215-00	D-2	3VL-H3915-00	D-7	3KJ-14312-30	B-7
4CU-E3616-00	B-6	4PC-F1571-10	B-15	4CU-F3171-PO	C-6	4MJ-F6215-10	D-2	1YU-14331-00	D-7	1YU-14331-00	B-7
4CU-E3621-00	B-6	4PC-F1572-00	B-15	4PC-F3171-PO	C-6	3VL-F6241-00	C-12	5T8-H3936-10	D-9	33A-14341-00	B-7
3WG-E4411-00	B-6	4PC-F1572-10	B-15	4CU-F3173-00	C-5	3VL-F6242-00	C-12	3VL-H3945-00	D-7	14T-14343-39	B-7
3WG-E4412-00	B-6	4PC-F171L-00	C-2			3WG-F6243-00	C-12		D-7	3KJ-14349-01	B-7
3WG-E4437-00	B-6	4PC-F171L-10	C-2	4CU-F3181-00	C-5	4MJ-F6280-00	D-2	4KH-H3962-00	D-7	3KJ-14353-22	B-7
3WG-E4451-00	B-6	4PC-F171M-00	C-2			4PC-F6311-00	C-12	4KH-H3975-10	D-7	14T-14384-00	B-7
3WG-E4452-00	B-6	4PC-F171M-10	C-2	4CU-F3183-00	C-5	3WG-F6312-00	C-12	3VL-H3976-10	D-7	1HV-14385-01	B-7
3WG-E4453-00	B-6	4MJ-F171N-00	C-2			3WG-F6329-00	C-12	3VL-H3980-00	D-7	367-14386-00	B-7
4PC-E4617-00	B-8	4MJ-F171N-10	C-2	4PC-F3317-00	C-6	4PC-F6351-00	C-12	4CU-H3987-00	D-7	2JA-14392-00	B-7
3WC-E4718-RO	B-8	3VP-F1721-00-P1	C-2	4PC-F3340-00	C-6	3VL-F636A-00	D-7	4PC-H4300-00	D-5	2JA-14397-00	B-7
3WG-E4766-00	B-8	3VP-F1721-00-9G	C-2	4MJ-F4111-00	C-7	4MJ-F639G-00	D-2	4MJ-H4311-00	D-5	4JP-14561-00	B-7
3WG-E4766-10	B-8	4MJ-F1751-00	C-3	4MJ-F414A-01	C-7	3WG-F6393-00	C-12	4PC-H4312-00	D-5	4KH-14610-00	B-8
3VL-E5128-00	B-9	3WG-F1771-00	C-3	4PC-F415E-00	D-2	4CX-F7111-00	C-14	4PC-H4314-00	D-5	3HK-14613-00	B-8
4CU-E5150-00	B-9	4PC-F1780-00	C-15	4MJ-F415A-00	C-7	2JW-F7114-00	C-7	4MJ-H4317-00	D-5	4FK-1490J-01	B-7
4CU-E5317-00	B-9	4PC-F1782-00	C-2	4MJ-F4183-00	C-7	4MJ-F7481-00	C-14	4PC-H4321-00	D-5	3AA-15513-00	B-10
3VL-E5363-00	B-9	4PC-F1782-10	C-2	4MJ-F4311-00	C-7	4MJ-F8311-00	C-15	3WG-H4324-00	D-5	3KJ-15528-00	B-10
4CU-E5371-00	B-9	4PC-F1783-00	C-2	4MJ-F4312-00	C-7	4CU-F8315-00	B-15	4MJ-H4337-00	D-5	3VL-15570-00	B-10
4CU-E5411-00	B-9	4PC-F1783-10	C-2	4MJ-F4610-00	C-7	4MJ-F834V-00	C-15	4CX-H4346-00	D-5	3KJ-15601-00	B-10
4CU-E5421-00	B-9	4PC-F2210-00	C-4	3WG-F4726-00	C-8	3WG-F8349-60	C-15	4CX-H4347-00	D-5	1NT-15630-01	B-10
4CU-E5451-00	B-9	3WG-F2241-00	C-4	4MJ-F473R-00	C-8	4MJ-F8371-00	C-15	4CX-H4352-00	D-5	3YJ-16611-00	B-11
4CU-E5451-00	B-9	4PC-F3102-PO	C-5	4PC-F4730-00	C-8	4MJ-F8385-00	C-15	4PC-H4359-00	D-5	4CX-16620-00	B-11
4CU-E5462-00	B-9	4PC-F3103-PO	C-5	4PC-F4730-10	C-8	4MJ-F8385-10	C-15	4PC-H4700-00	D-6	17L-16626-00	B-11
4CU-E5532-00	B-10	4CU-F3110-00	C-5	4MJ-F4747-00	C-8	3WG-H2129-00	C-8	4MJ-H4721-00	D-6	3WG-17608-00	B-11
3WG-E5620-00	B-10			4MJ-F475M-00	C-8	3WG-H2151-00	D-9	4MJ-H4743-00	D-6	3VP-17641-00	B-11
4CU-E5650-00	B-10	4CU-F3111-00	C-5	4PC-F4780-00	C-8	3WG-H2370-10	D-9	4BA-H5130-00	D-9	1NT-17653-00	B-11
3VL-E5657-00	B-11			4KH-F5115-00	C-9	3WG-H2372-00	D-9	3VL-H5720-10	D-9	3GF-17660-02	B-11
3VL-E5659-00	B-10	4PC-F3126-PO	C-5	4KH-F5117-00	C-9	4PC-H2501-00	D-8	3RW-W0041-02	C-13	24G-17664-00	B-12
4CU-E5659-00	B-9	4PC-F3136-PO	C-5	3WG-F513A-00	C-11	3WG-H2541-00	B-10	2JL-W2536-10	C-11	3KJ-17684-00	B-12
4CU-E5673-00	B-10	4CU-F3141-PO	C-5	4PC-F5168-00-35	C-9	4MJ-H2552-00	D-8	4PC-X1511-00-P1	B-15	3VP-21535-00	C-15
4CU-E6111-00	B-11	4PC-F3141-PO	C-5	3VL-F5170-10	C-9	4PC-H2590-00	D-9	4PC-X1511-00-9G	B-15	35R-21796-00	C-15
4CU-E7410-00	B-13	4CU-F3144-00	C-5			4KH-H2910-00	D-7	4PC-X1711-00-P1	C-2	164-22216-00	B-9

NUMERICAL INDEX

PART NO.	GRID NO.	PART NO.	GRID NO.	PART NO.	GRID NO.	PART NO.	GRID NO.	PART NO.	GRID NO.	PART NO.	GRID NO.
22F-23411-01	C- 6	90119-06043	D- 6	90241-10015	C- 8	92907-06200	B- 8	97707-30605	B- 8	99510-12016	B- 9
22F-23412-01	C- 6	90119-06044	B- 15	90249-12008	B- 15	92907-06600	C-12	97707-40512	C-15	99530-10014	B- 9
22F-23414-01	C- 6	90119-06118	C-14	90280-03017	B- 3		B- 4	97707-40620	D- 6		B- 9
3VP-23416-00	C- 6	90149-06113	B- 8	90338-07818	D- 2		D- 9	97707-50016	C- 2		
2E9-24182-00	C- 7	90149-06184	C- 2	90380-15083	B-10	92907-10600	D- 3		C- 2		
53L-24261-00	D- 9	90149-06250	D- 8	90387-06067	B- 8	92995-06100	B- 7		C-14		
3KJ-24500-01	C- 7	90153-06052	B-10	90387-064A4	C-14	93101-20138	B- 3		C-15		
4X8-24565-00	C- 7	90159-05121	D- 2	90387-067V1	B- 4	93102-17342	B-11		C-15		
3VP-24717-00	C- 8	90159-0L	D- 5	90387-068C7	B- 6	93102-20371	B- 3		D- 2		
4JC-25190-00	C- 9	90159-06835	C-15	90387-10079	C- 9	93102-22314	B-13		D- 4		
3KJ-25351-00	C-11	90163-05006	B-15	90387-135U9	B-11	93104-19097	D- 3		D- 5		
2NA-25831-00	C-10	90167-05041	C- 2	90387-156U0	B- 3	93106-20001	C- 9		D- 6		
3RW-25852-00	C-13		C- 2	90445-052G4	B- 5	93109-33052	B-11	97707-50025	D- 5		
3RW-25854-00	C-13		C- 8	90445-07434	C- 7	93210-06550	B-11	97707-50125	B- 6		
56A-25867-00	C-13	90167-05055	C- 2	90445-09304	B- 5	93210-07540	C-11	97707-60540	B- 4		
3RY-25870-02	C-13	90170-10219	B-11	90460-32242	B- 6	93210-14104	B- 9	98501-04006	D- 3		
3KJ-26329-00	B- 7		D- 3	90464-13804	C-12	93210-23614	B-10	98507-03008	B- 6		
3VR-28313-00	C-15	90170-10317	B-11		D- 2	93210-38687	B-11	98507-05010	C-12		
2JA-81403-M0	D- 3	90179-06403	C- 8		D- 9	93210-65752	B- 4		D- 3		
3YJ-81800-01	B-10	90179-06411	C-12	90465-18147	D- 9	93300-63813	B-11	98507-05014	B- 5		
1YU-81801-M0	B-10	90179-07381	B- 2	90467-08003	B- 5	93306-00302	B-11	98507-05010	B-11		
29U-81950-93	D- 9	90179-25033	C- 6	90467-09006	C- 7	93306-00316	B- 9		D- 8		
3KJ-81960-11	D- 8	90179-28415	B-12	90467-11106	C- 7	93306-20006	B-13		D- 9		
3UC-82100-10	D- 9	90183-05042	C- 2	90467-24140	B- 6	93306-20346	B-13	98507-05012	B- 9		
3KJ-82310-01	D- 9		C- 2	90468-02033	B- 5	93306-20458	B- 3		B-10		
1YT-83311-00	D- 5		C-14		B- 5	93306-30003	C- 9	98507-06016	B- 4		
	D- 6		D- 6	90468-12006	C- 4	93310-210M0	B- 3		D- 3		
3NW-83371-01	D- 8	90185-10154	B-14		C-14	93310-257R1	B-10	98507-06020	B- 4		
2NA-83922-01	D- 7		C- 9	90480-10468	B- 4	93420-40064	B-13		B- 6		
4CU-83980-00	D- 7		C-12	90480-12237	B- 8	93450-11120	B- 3		B- 9		
31L-84714-00	D- 6	90185-10822	C- 4	90480-12497	B- 4	93503-16010	C- 6		D- 9		
3VP-84725-00	D- 6	90185-14150	C-11		B- 6	93603-12007	B- 5	98507-06025	B- 9		
2JA-85370-00	D- 9	90201-06412	B-11	90501-10312	D- 7	94701-00110	B- 2	98507-06035	B- 9		
3KJ-85540-01	D- 9	90201-C6815	B- 6	90501-29517	B-14	95027-06016	D- 8		B- 9		
2JA-85550-00	D- 3	90201-08087	B- 9	90501-357F3	B-12	95607-06100	D- 7		B- 9		
3KJ-85560-00	D- 3	90201-08088	B-10	90506-15260	C-11	95607-12200	B-14	98507-06065	B- 9		
2JA-85580-M0	D- 3	90201-086A3	C- 8	90506-32464	C-14	95707-05500	D- 9	98511-05020	D- 3		
4MJ-85752-00	D- 9	90201-10118	C-13	90508-32609	B-10	95707-08500	C-11	98580-03006	B- 7		
53L-85753-00	D- 9	90201-123K4	B-13	90560-06366	C- 7	95807-06012	B-14	98580-04016	B- 7		
90101-06278	C-11	90201-136P4	B-11	91A20-07014	B- 9		B-15	98580-05014	B- 7		
90105-08121	C- 4	90201-142M6	C-11	91316-06020	B- 6	95807-06016	C- 6	98580-06016	B- 7		
90105-10036	C-12	90201-154E9	B-10		B-10	95807-06016	B- 9	98706-04012	C-13		
90109-063F1	C- 8	90201-17255	C-11	91317-06025	C-13	95817-08030	B- 8	98907-06010	C- 6		
90109-063F5	C- 7	90202-10120	C-14	92901-04100	B- 7	95817-08040	B- 8	98907-06016	B- 8		
90109-06577	D- 7	90208-10012	B-11		D- 3	95827-08012	C- 4	99009-15400	B-10		
90110-10821	C-10	90208-12049	B-13	92907-03600	B- 6	95827-08030	C-10	99009-17400	B- 9		
90116-07353	B- 2	90214-13055	B-11	92907-06100	B- 4	95827-10030	C- 6		B-11		
90119-06042	C- 3	90240-10137	C-14		D- 9	97007-06016	D- 9	99009-19400	B- 5		